

2a. **Scenic Construction:** back view and front view for one flat

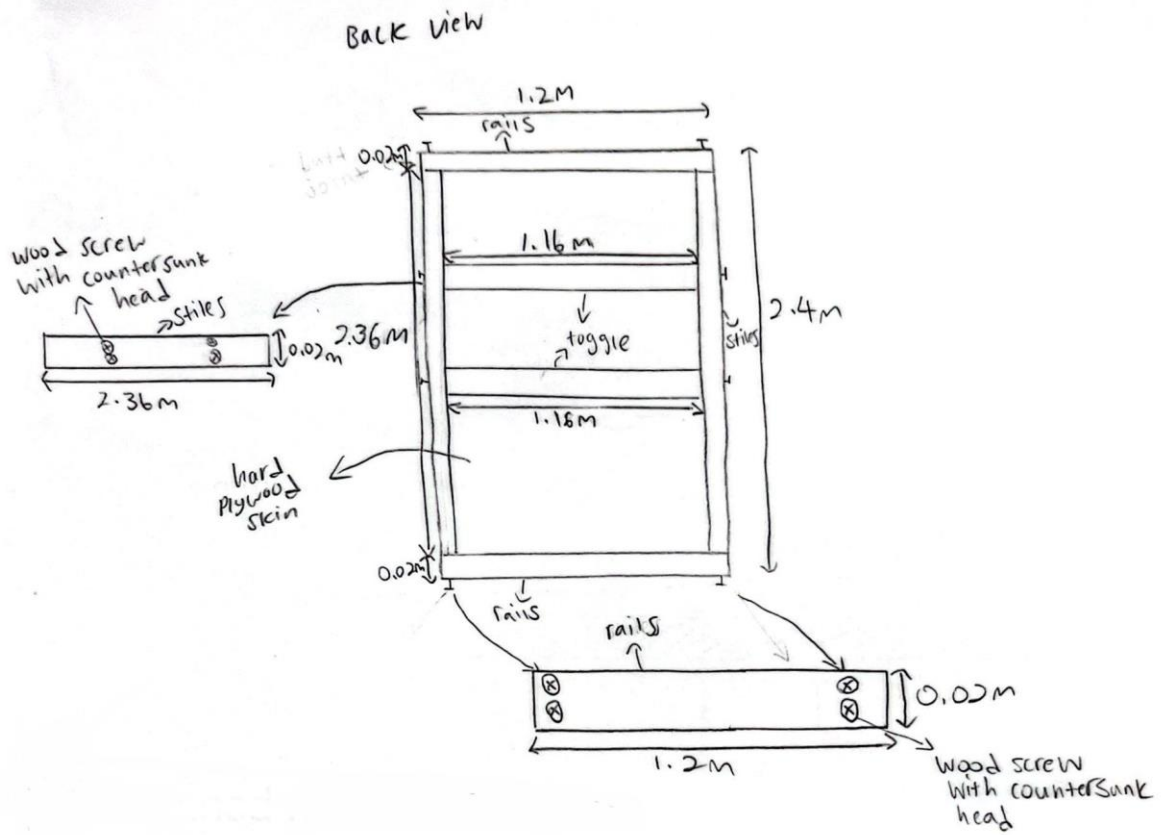

Front view

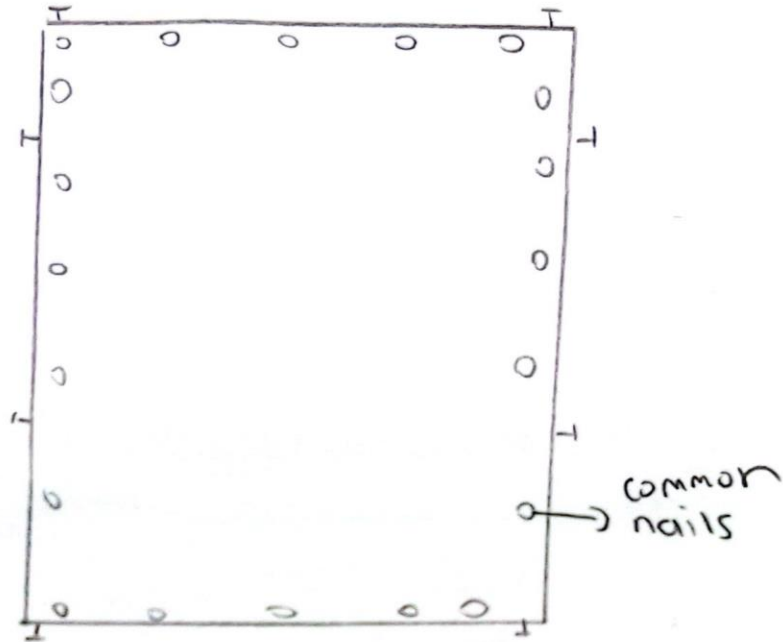

**Backview for flats
when connected at
venue**

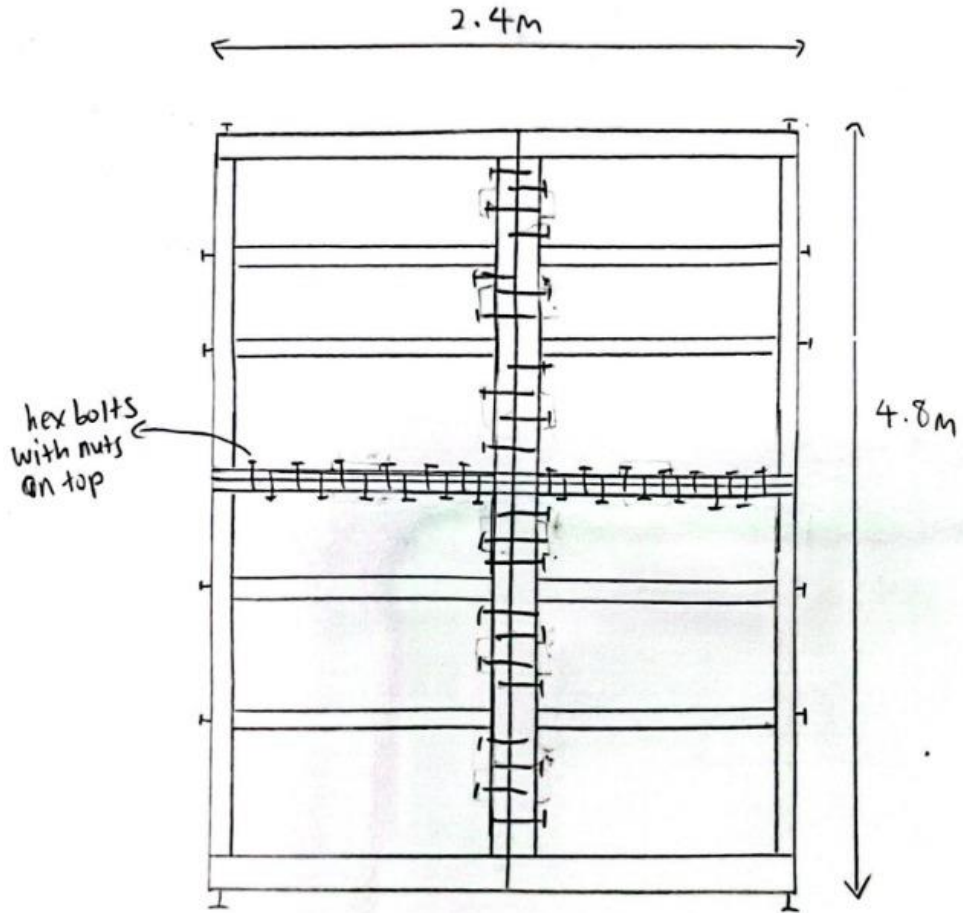

Back and sideview of connected flats with stand for finale

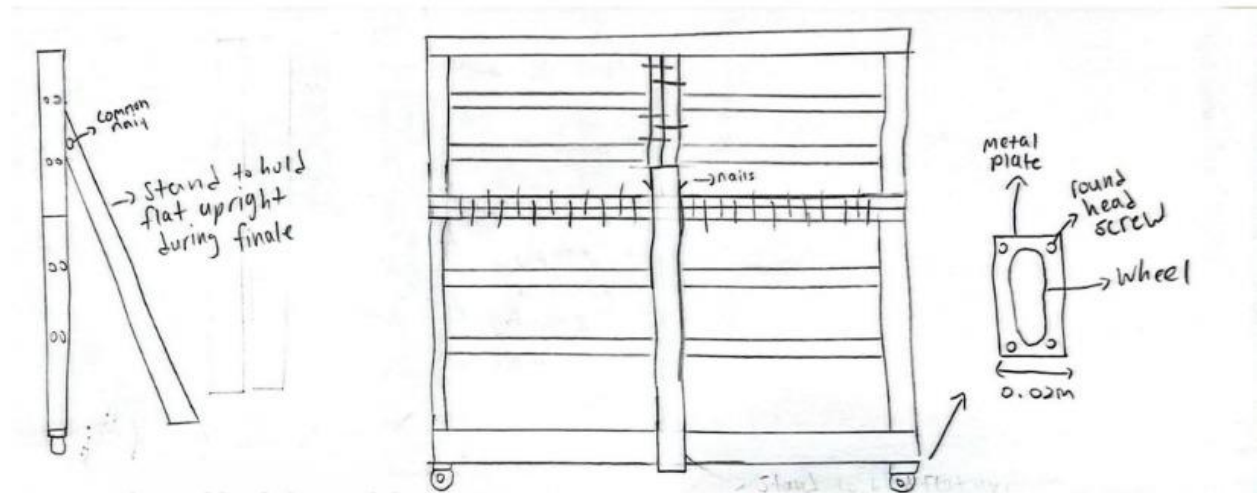

cutting list: toggle(8pcs 1.16m)

Stiles(8 pcs 2.36m)

Rails(8 pcs 1.2m)

Hard plywood skin(4 pcs 2.4m by 1.2m)

Hardware/equipment list

Hammer(1 piece)
Nails (22 pieces)
F-Clam (3 pieces)
Wired jigsaw (1 piece)
Impact drill (1 piece)
Wood screw with countersunk head (64 pieces)
Hex bolts (47 pieces)

Nut head(47 pieces)
Wheels (2 pieces)
Metal plate (2 pieces)
Round head screw (8 pieces)
Electric drill (1 piece)
Measuring tape (1 piece)
Wrench (4 pieces)

Top view for floor

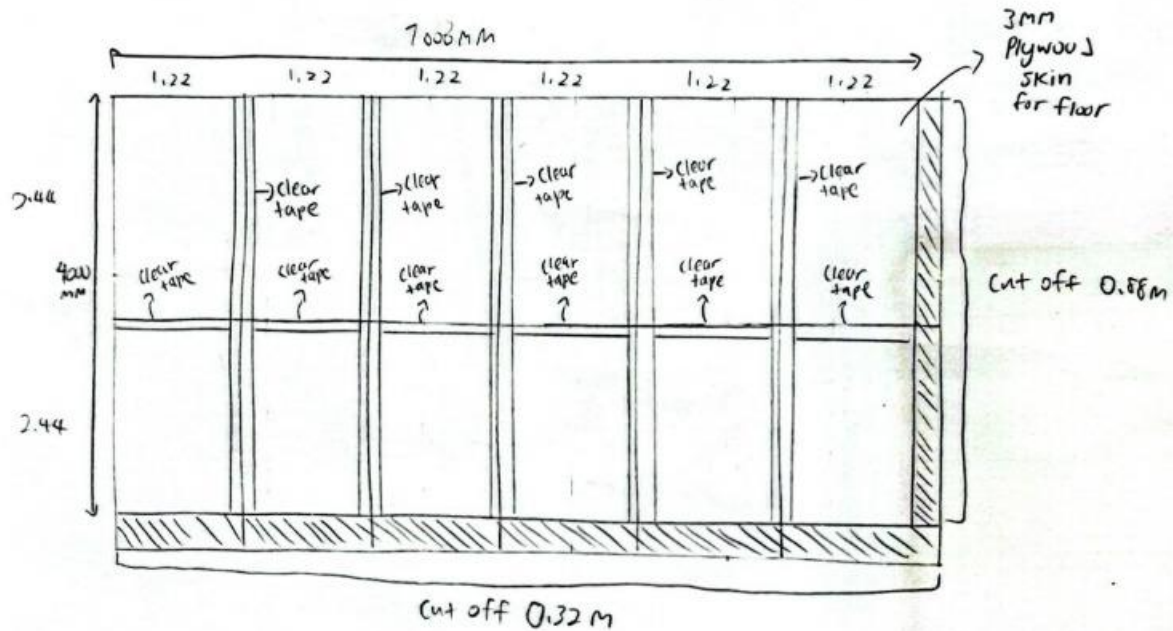

Cutting list: 3mm Plywood skin (12 pieces 1.22m by 2.44m)

Cut off 0.88m to make 4.88m to 4m and 0.32 for 7.32m to 7m

Hardware/equipment list for skin flooring
Clear tape (16 pieces)
Weights to put at ends of the floor (4 pieces)
Wired jigsaw (1 piece)
Measuring tape (1 piece)
Water based paints (24 pieces)
Brushes (24 pieces)
Rollers (12 pieces)

2b. Audience risers

Front view for audience risers

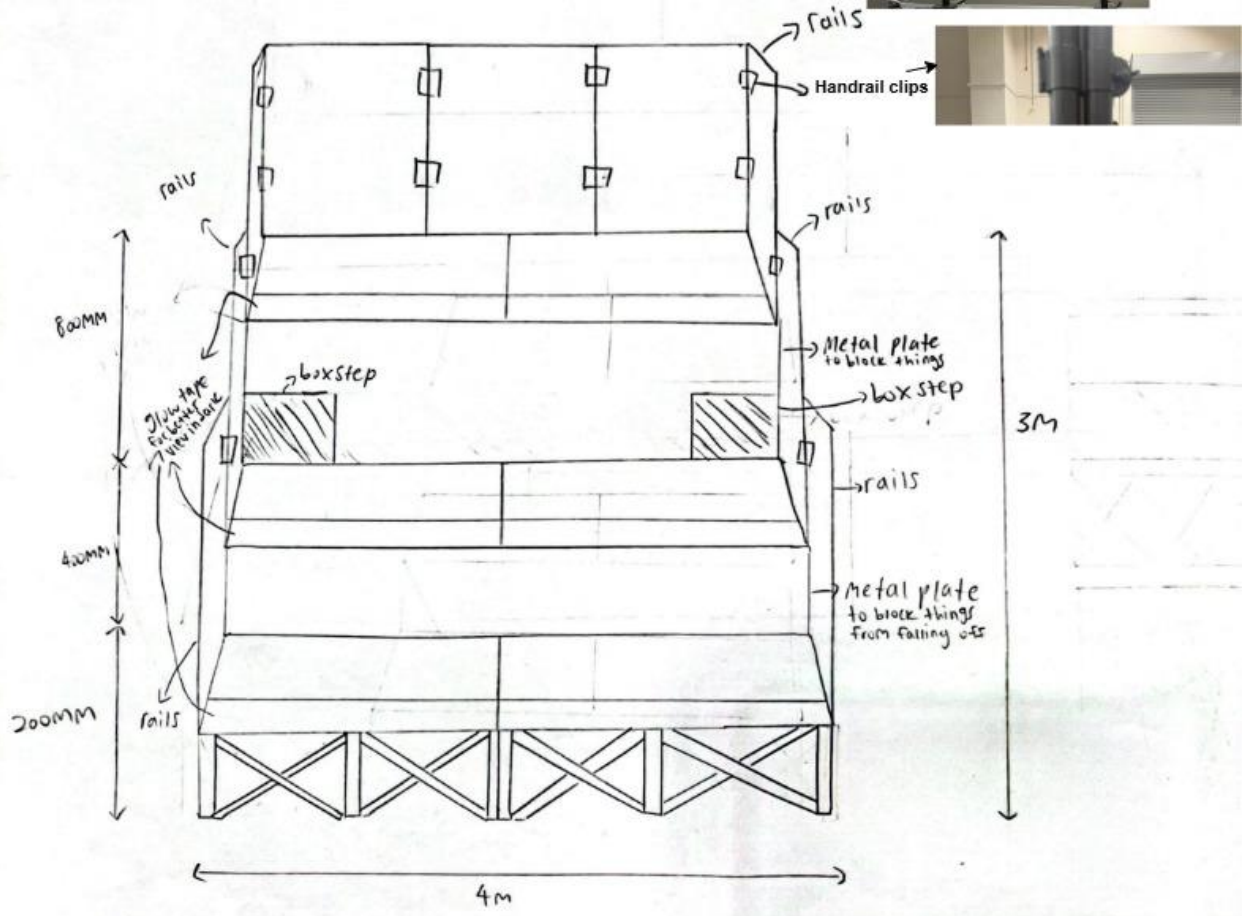

Sightlines

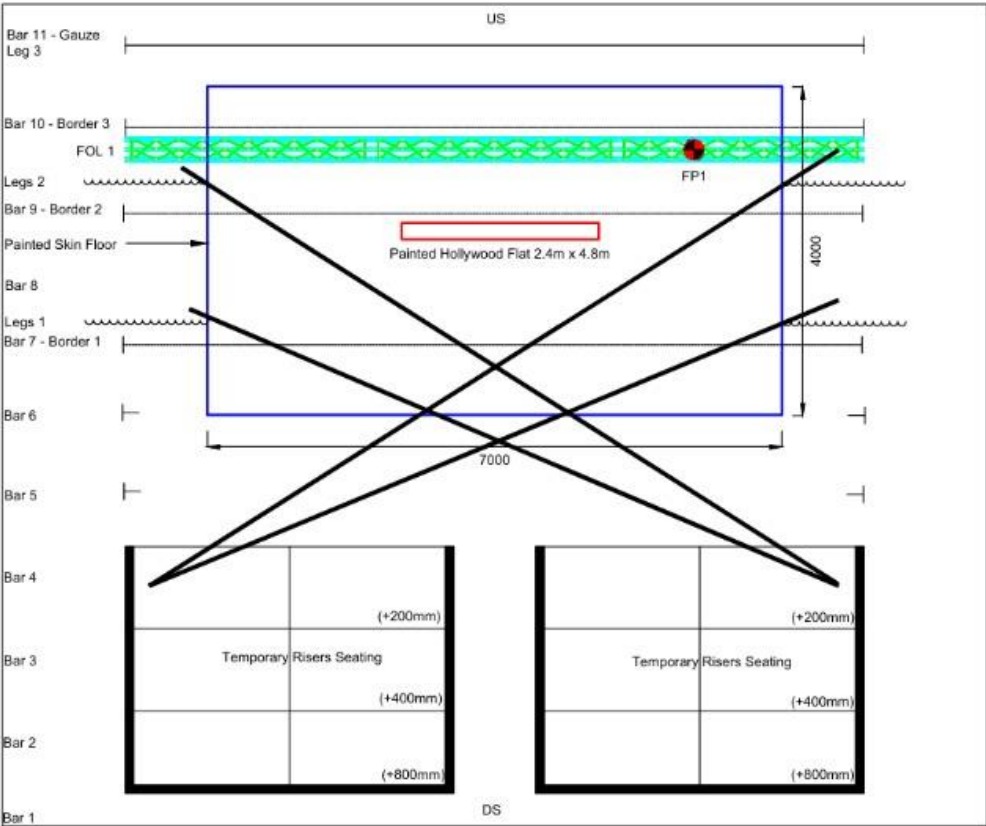

Hardware/equipment list For Audince risers	
2M x 1M platform top (12 pieces)	
200mm legs (4 pieces)	
400mm legs (4 pieces)	
800mm legs (4 pieces)	
Box step (4 pieces)	
Barricades/rails(20 pieces)	
Handrail clips/handleclips (24 pieces)	

Allen key (8 pieces)	
Glow tape (12 pieces)	
Metal plate to block items (3 pieces)	
Fly cases (5 pieces)	

2c: **Soft goods**

Annex A

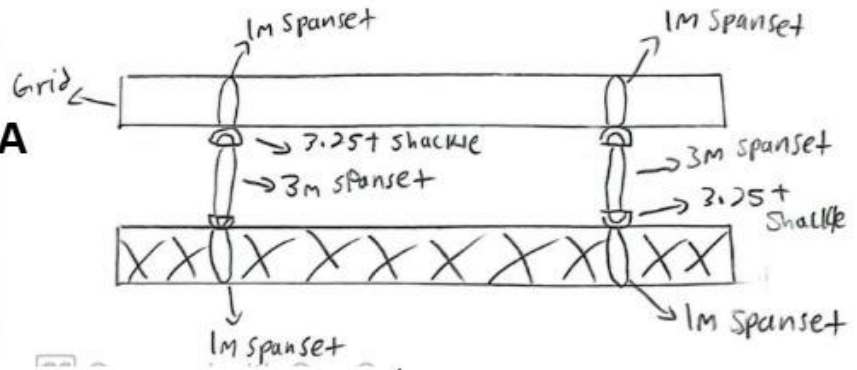

Front view for borders and legs

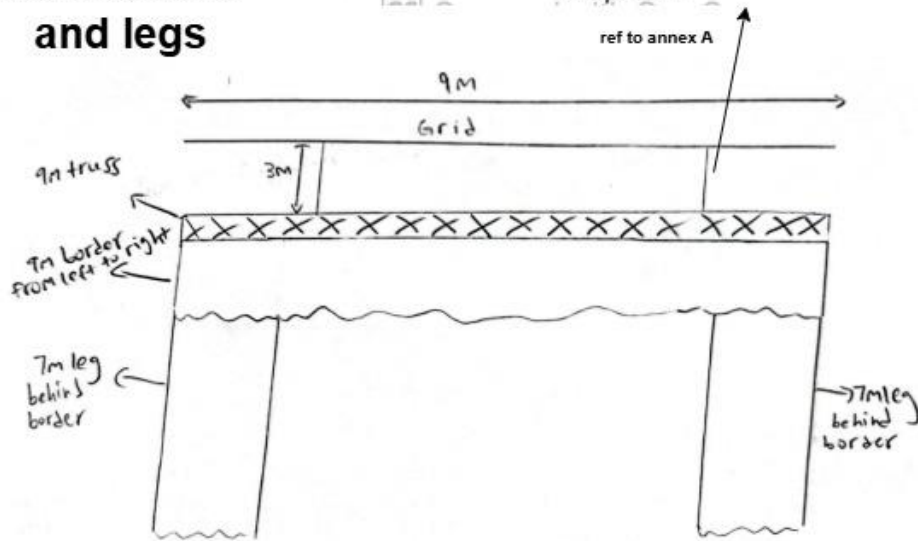

Annex A

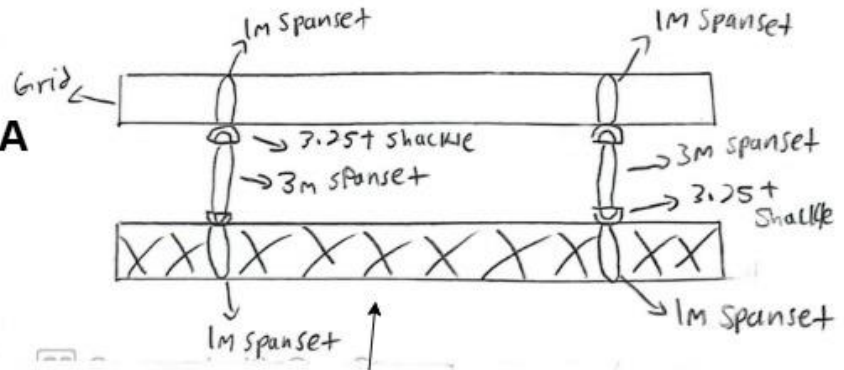

Front view for Gauze

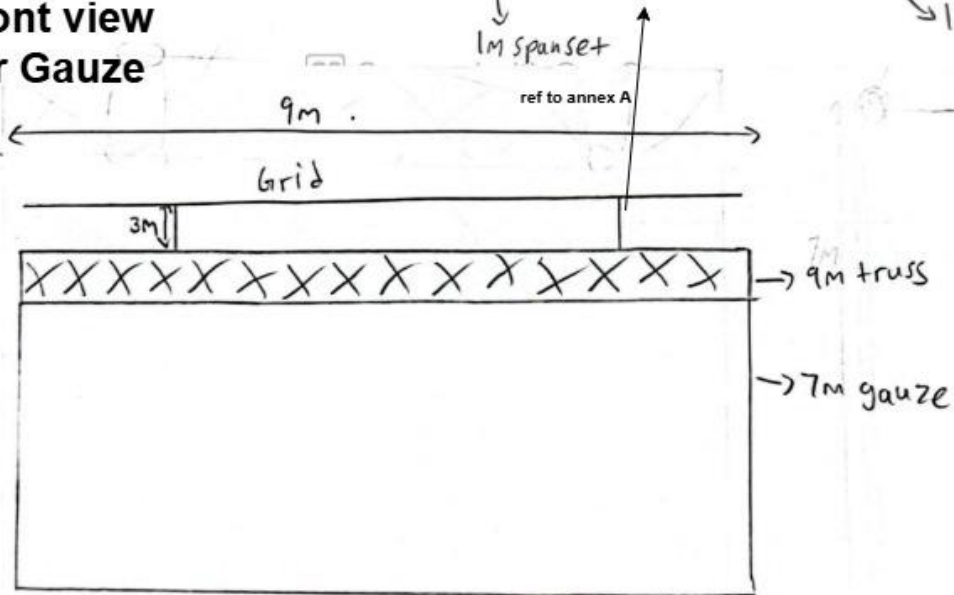

Annex A



Side view for all soft goods

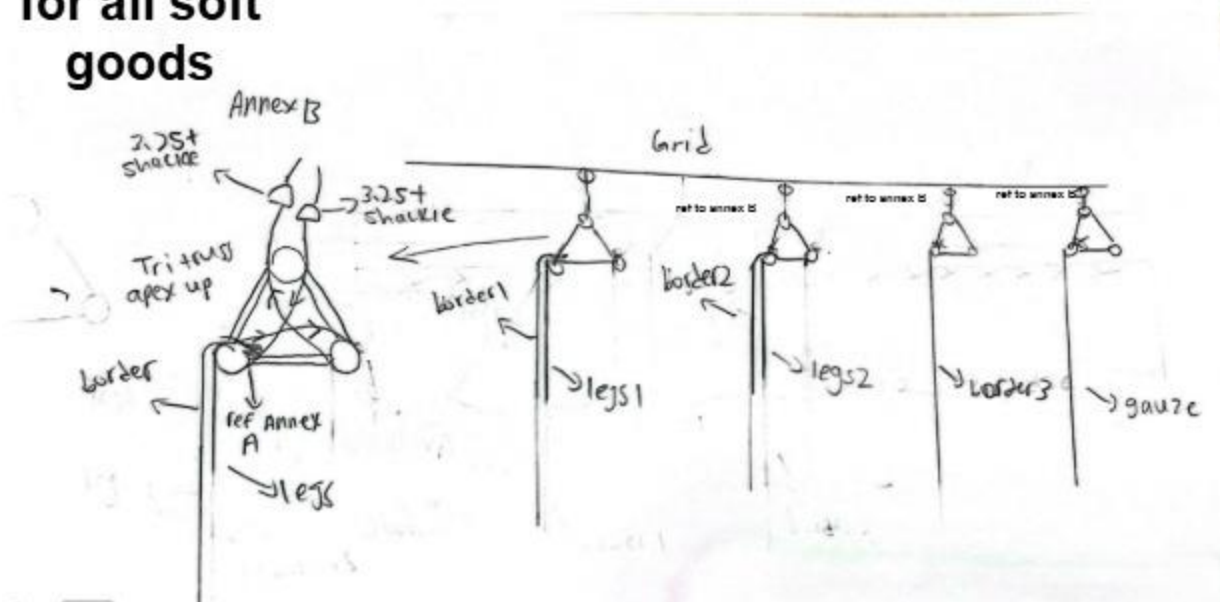

Hardware/Equipment list for Soft goods

Borders (3 pieces)
Legs (4 pieces)
Gauze (1 piece)
3m Tri truss (12 pieces)
Spigot (24 pieces)
Pins (48 pieces)
Clips (48 pieces)

3.25t shackles (16 pieces)
1m spanset (8 pieces)
3m spanset (4 pieces)
Mallet (8 pieces)

3. Schedule of setup works

Time	Team A- Scenic(6 people)	Team B- Soft goods(8 people)	Team C- Audience rises (5 people)
10:00 am to 10:30am	Bring all already cut flats and skin into venue	Bring in 3m Tri Truss to venue	Push in fly cases and bring equipment into the venue
10:30am to 11am	Paint the skin flooring	Bring in 3m Tri Truss to venue	Bring out platform and legs from fly cases
11 am to 11:30 am	Paint the skin flooring	Connect 3m truss together to make 9m using spigot, clips, pins and mallet	Connect the legs to the tops and set them up in position
11:30 to 12pm	Paint the skin flooring then leave it out to dry by the side	Tie the borders, legs and gauze onto the truss	Insert metal plates in front of both 400mm and 800mm legs
12pm to 12:30pm	Connect hollywood flat together with hexbolts and nuts	Tie the borders, legs and gauze onto the truss g shackles	Place box steps on 400mm top
12:30 to 1pm	Attach wheels and stand to the flat, set it aside	Tie 1m spansets on the grid and connect it to a 3m spanset using shackles	Add barricade to the sides of the tops using allen key
1pm to 2pm	Lunch	Lunch	Lunch

2pm to 3pm	Place floor skin on the stage floor and line them up for connection	Tie 1m spansets on the grid and connect it to a 3m spanset using shackles	Paste glow tape onto the edge of the top
3pm to 3:30pm	Paste clear tape on skin to keep the skin together	Tie 1m spansets onto the tri truss on the ground	Help Team B to tie if needed
3:30pm to 4:30pm	Place weights on the edges of the skin to prevent movement then help team B if finished early and if they need help	Lift the truss up to connect the spanset with the 3m spanset using shackles	Help Team B to lift if needed
4:30pm to 5pm	Safety checks to make sure things are secure and safe	Safety checks to make sure things are secure and safe	Safety checks to make sure things are secure and safe
5pm to 6pm	Rehearsals for Performers and lighting department	Rehearsals for Performers and lighting department(Team should watch and make adjustments if needed)	Rehearsals for Performers and lighting department
6pm to 6:30pm	Reset and prepare for show	Reset and prepare for show	Reset and prepare for show