

# ME 4504 PROJECT REPORT

**A SUITCASE SIZE- MARS ROVER'S  
CHASSIS STATIC ANALYSIS**



## **SUBMITTED BY**

**Sazidur Rahman Chowdhury - 200011110**  
**Nifat Mouddit Nizhum - 200011119**  
**Tashdeed Hameem Khan - 200011121**  
**Mustafa Omar Nasif - 200011123**  
**Samiuzzaman - 200011133**  
**Md. Samiul Ibn Safayet - 200011150**  
**Iftexhar Ahmed - 200011153**

## **SUBMITTED TO**

**IFAT RABBIL QUDRAT OVI**  
**LECTURER, MPE,**  
**IUT.**

## **Introduction:**

The Mars rover is a vehicle that has been designed to traverse the rugged terrains of Mars and collect samples of various items on Mars's surface. Scientists over the years have tried to explore the possibility of life on Mars. Such explorations have been mostly done using rovers. Hence, rovers need to be specially designed to traverse all kinds of terrains and must be equipped with state-of-the-art technology.

A common design element of most rovers over the years, which is the rocker-bogie mechanism. The rocker-bogie mechanism has quite a lot of advantages and is hence a well-established mechanism. The main advantage is that it ensures that all the wheels of the rover are in contact with the ground at all times. This advantage is key to creating a stable all-terrain system. Consequently, the traction the rocker-bogie provides is equal and reliable, allowing a smooth running even on the uneven terrains.

Mars exploration rover chassis provided with a three degree of freedom (Dof) compact swerve drive mechanism. The powerful drive motors and the suspension system used aid the rover in traversing the terrain at more significant speeds than a rocker-bogie suspension-based rover could achieve without compromising on its stability. The symmetrical design of the rover made maneuvering more comfortable and faster.

## **Design:**

The design of the rover is to allow it to traverse rough and rocky terrain which at present is not possible using conventional vehicle design. Therefore, the major aim is to design a rover which has an effective mechanism removing the disadvantage of modern day rovers. The chassis designed is in accordance with the set of rules and requirements that have to be met in order to contest in different events.

Proposing a square shaped suitcase size rover for the ease of transporting in various competitions such as ERC, IRC, URC etc. The purpose of this design is to validate such shape rover's efficiency by applying simulated conditions with different materials. The chassis needs to handle additional weight of Arm, Deep sampling module and other components.

## **Material Selection:**

For the selection of materials, we have considered four main factors –

- I. The strength of the material
- II. The weight of the material
- III. The manufacturability
- IV. Cost-effectiveness
- V. Deformity
- VI. Corrosivity in humid environment.

**Stainless Steel** is an alloy of Iron that is resistant to corrosion and is usually rustless. The composition of this alloy varies between groups and different grades of SS. The most corrosion resistant SS is Austenitic Steel, which has the composition of 16-26% Chromium, up-to 35% Nickel and other elements. The most common grade is 18/8, or 304, has 18% chromium and 8% nickel composition.

**Aluminum** has a density lower than most metals, almost one-third of that of steel, causing it to weigh lesser. The grade of Aluminum used in this study is Aluminum 6062, which is an aluminum alloy of magnesium silicide type with corrosion resistance to salt water.

### Why did we use stainless steel in this study?

The presence of chromium induces a passive film of rust resistant layer protecting the iron from oxygen. Hence SS is highly corrosion and rust resistant.

When it comes to strength, Stainless Steel is much superior to most metals being three times stronger than ordinary steel. Tensile strength of grade 304 SS is about 621 MPa.

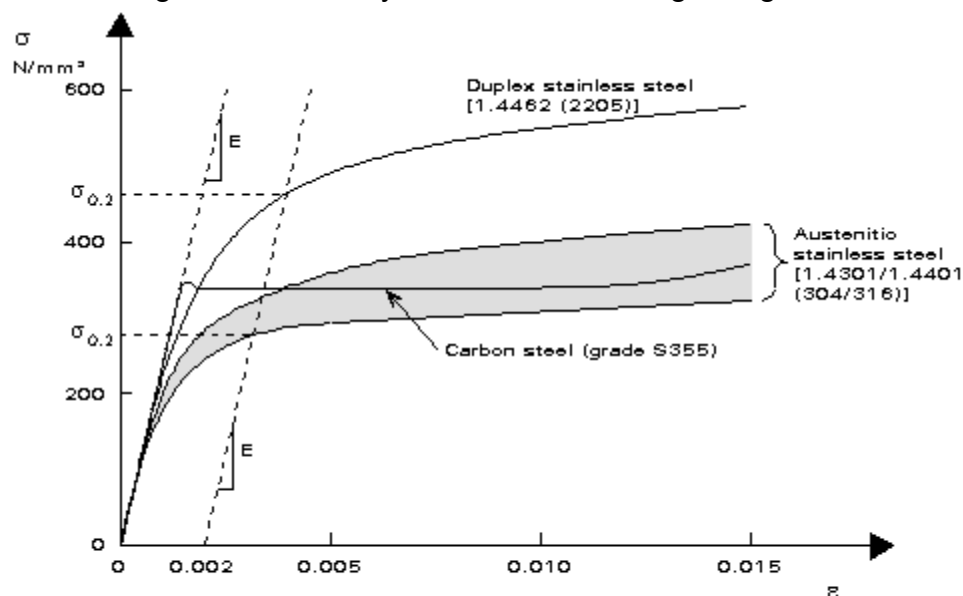

*Typical stress-strain curves for stainless steel and carbon steel*

In regards to Heat tolerance, SS has a clear advantage. The maximum operating temperature of Grade 304 stainless steel is 870°C and melting point is at around 1400C. Thus stainless steel provides higher heat resistance.

When it comes to manufacturability stainless steel is a bit more rigid and may crack if pushed too hard during the manufacturing process. This may be a disadvantage in several applications for which we use aluminum, which is discussed later.

Stainless steel is also very heavy. Its weight/density is 2.5 times of aluminum, compensating which we take aluminum into consideration.

With high strength, high heat resistance, stainless steel is also very cost effective. A pound of steel costs less than a pound of aluminum.

### **Why did we use Aluminum in this study?**

When it comes to weight and density, steel is 2.5 times heavier than aluminum. However, at half the weight, aluminum can still offer comparable reliability to a comparable steel structure. Aluminum has a density lower than that of other common metals; about one-third that of steel. Which makes aluminum a very good prospect since our goal is to reduce the weight and size of the Mars Rover.

Aluminum when oxidized, a passive layer of aluminum is created obstructing further oxidation. Hence aluminum is corrosion resistant like stainless steel. Despite that aluminum may be subjected to corrosion due to the presence of sulfides or chlorides. For this reason, Aluminum 6062 grade is used in this study which is corrosion resistant in salt water.

Because of its smooth construction and malleability, aluminum can form deep, precise, and intricate spinings, offering handlers a great deal of design freedom.

Aluminum provides strength in colder environments but is less useful in high-temperature applications due to its lower melting point. The melting point of 304 stainless steel is approximately 1400C, while the majority of aluminum alloys will become dangerously soft at 400C.

Aluminum, not being a good heat resistant, is very conductive to heat.

Overall, when the size, weight, heat conductivity, corrosion resistance, manufacturability are prioritized, aluminum 6062 provides the best prospect.

When strength of material, tensile strength, heat resistance or tolerance, corrosion resistance, cost efficiency are at focus, 304 stainless steel does the job better.

Considering the above factors we have chosen Stainless Steel and Aluminum to be primarily selected materials for simulation.

## **Modeling:**

The total experiment was designed in SOLIDWORKS software. SOLIDWORKS is a popular Computer Aided Design (CAD) software widely used in the engineering, research and design industries developed by Dassault Systemes. It is basically used to design 3D Modeling, Simulation and Product Design. It enables users to create detailed and accurate designs. It facilitates the entire product development process from concept to manufacturing. It is basically a user-friendly software for the students and researchers. This software is widely used to design by Mechanical, Electrical and Industrial engineers.

We have modeled a Rover Chassis in this software. In order to design and manufacture the chassis, continuous optimization is done. As the FOS has to be higher, deflection should be minimal. The rectangular channel of thickness 3.05 mm is capable of withstanding both vertical and longitudinal load. The model and channel specifications that satisfies the component restraints are as follows:

- **Final design of the chassis and base dimension:**

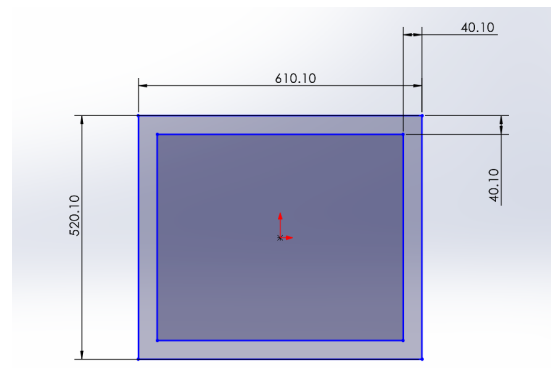
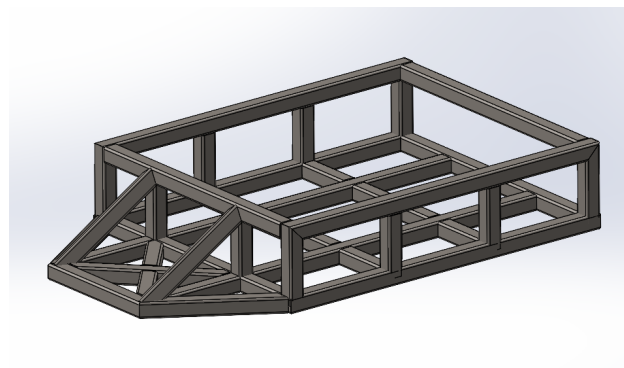

All the dimensions are in the MMGS unit system. The Base length and width is 610.10 mm and 520.10 mm respectively. The thickness is 40.10 mm. The chassis analysis was done after designing the final chassis.

- **Channel Specifications:**

Material Specification	Al 1060
Type of channel used	Rectangular channel
Thickness	40.10 mm
Chassis Dimensions	827.4 mm * 520.10 mm
Weight	7.2 kg

## Analysis:

### Basic ANSYS Structure

ANSYS is a comprehensive general-purpose finite element computer program, which is capable of performing static, dynamic, heat transfer, fluid flow, and electromagnetism analyses. The current version of ANSYS has a completely new look, with multiple windows incorporating Graphical User Interface (GUI), utility menu, input window, and a toolbar. Today, you will find ANSYS in use in many engineering fields, including aerospace, automotive, and electronics because the ANSYS is a very powerful and impressive engineering tool that may be used to solve a variety of problems.

Treatment of engineering problems generally contains three main parts: create a model, solve the problem, analyze the results. ANSYS, like many other FE-programs, is also divided into three main parts (processors) which are called preprocessor, solution processor, postprocessor. Other software may contain only the preprocessing part or only the post processing part. During the analysis we will communicate with ANSYS via a Graphical User Interface (GUI), which is seen in figure.

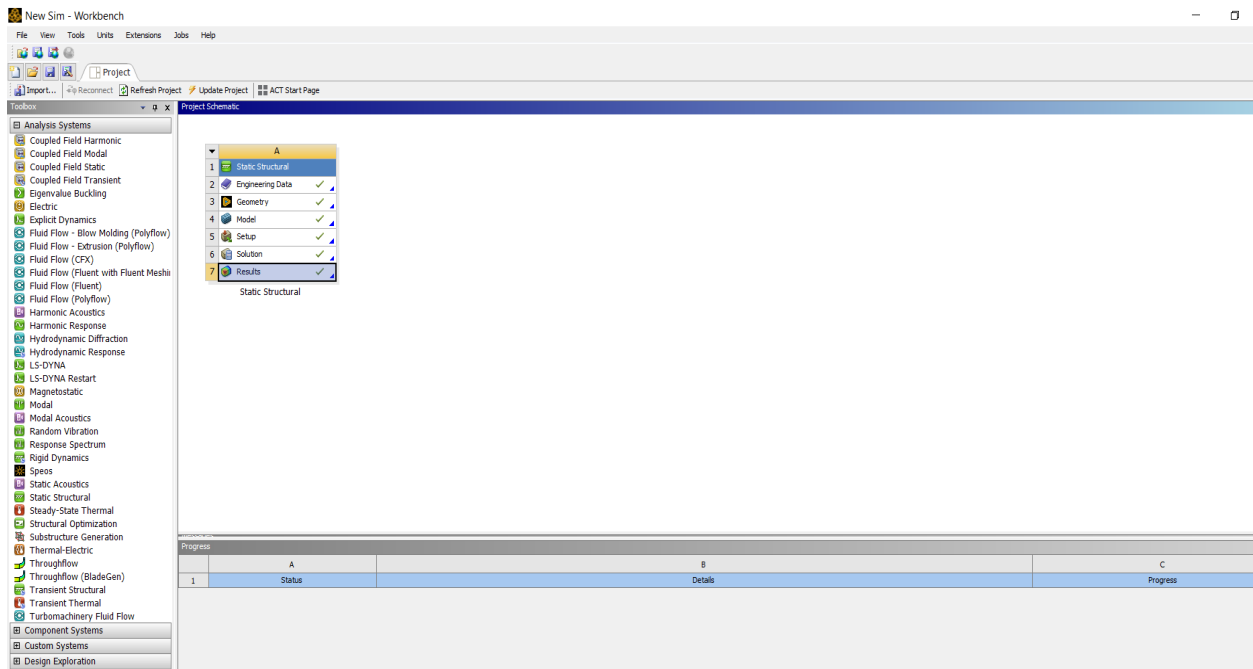

# Guide to simulation:

## 1. Step file in Ansys:

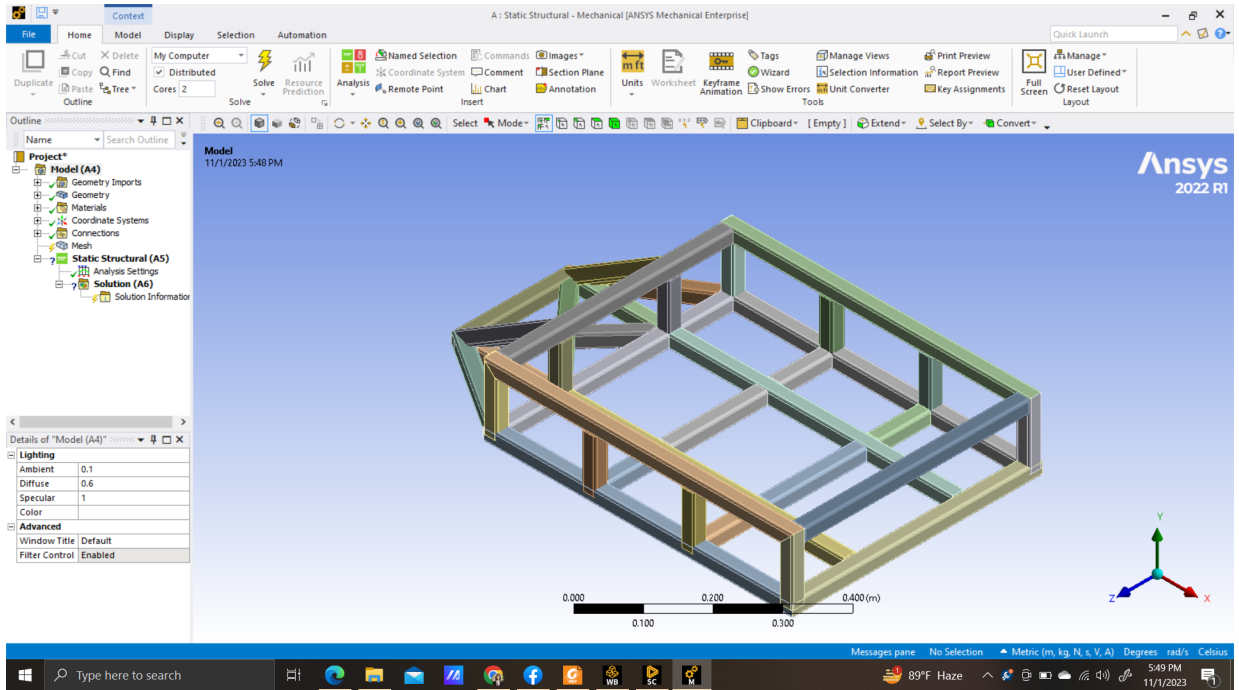

## 2. Running Auto mesh failed, so manually meshing was done.

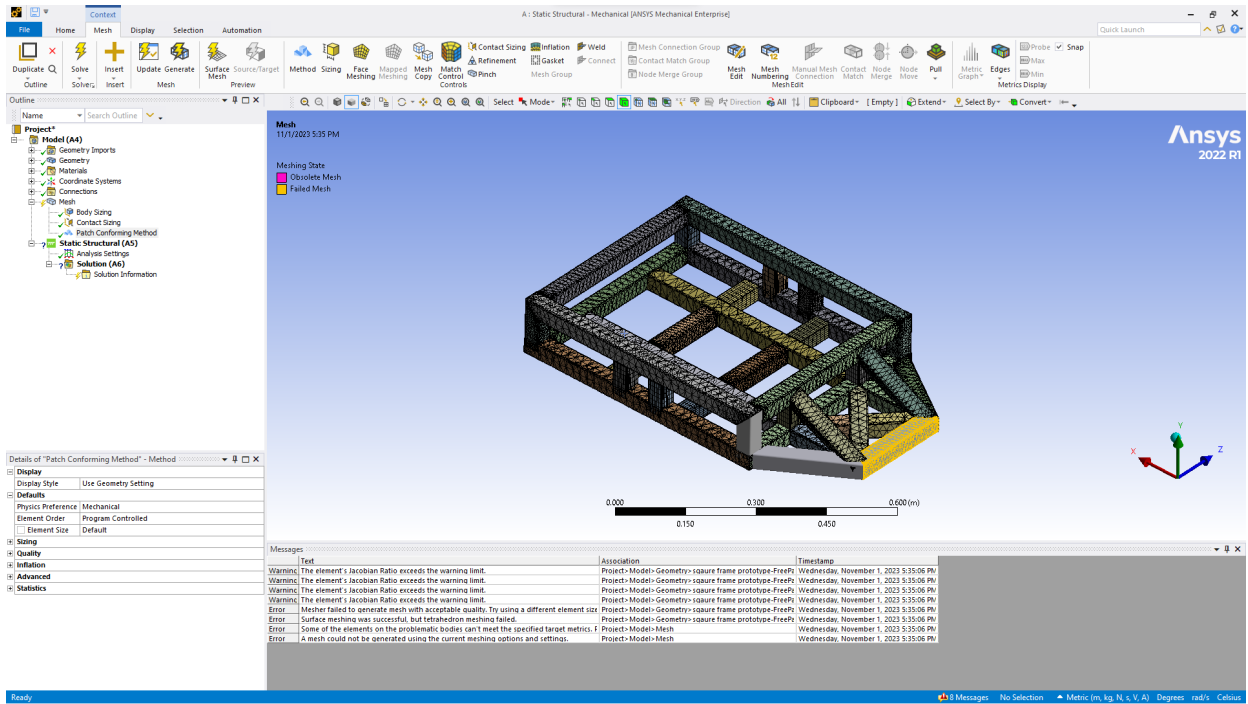

## Meshing:

**Generate element mesh:** The problem is treated by nodal points. The nodes are connected to form finite elements, which together form the material volume. Depending on the problem and the assumptions that are made, the element type has to be determined. Common element types are truss, beam, plate, shell and solid elements. The element mesh can in ANSYS be created in several ways. The most common way is that it is automatically created, however more or less controlled. For example, you can specify a certain number of elements in a specific area, or you can force the mesh generator to maintain a specific element size within an area. Certain element shapes or sizes are not recommended and if these limits are violated, a warning will be generated in ANSYS. It is up to the user to create a mesh which is able to generate results with a sufficient degree of accuracy.

## Mesh Parameters:

The rover chassis structural analysis was conducted using a structured mesh composed of tetrahedral and hex dominant elements. The mesh size was carefully chosen, with an average element size of 10 mm and a minimum element size of 5 mm. Notably, approximately 70% of the elements had a size of 5 mm, emphasizing a refined mesh in critical areas.

## Mesh Quality Metrics:

### Aspect Ratio:

The aspect ratio of the mesh elements ranged from a minimum of 1.604 to a maximum of 150.19, with an average of 5.6045. The standard deviation of 1.3071 indicates the distribution of aspect ratios across the mesh.

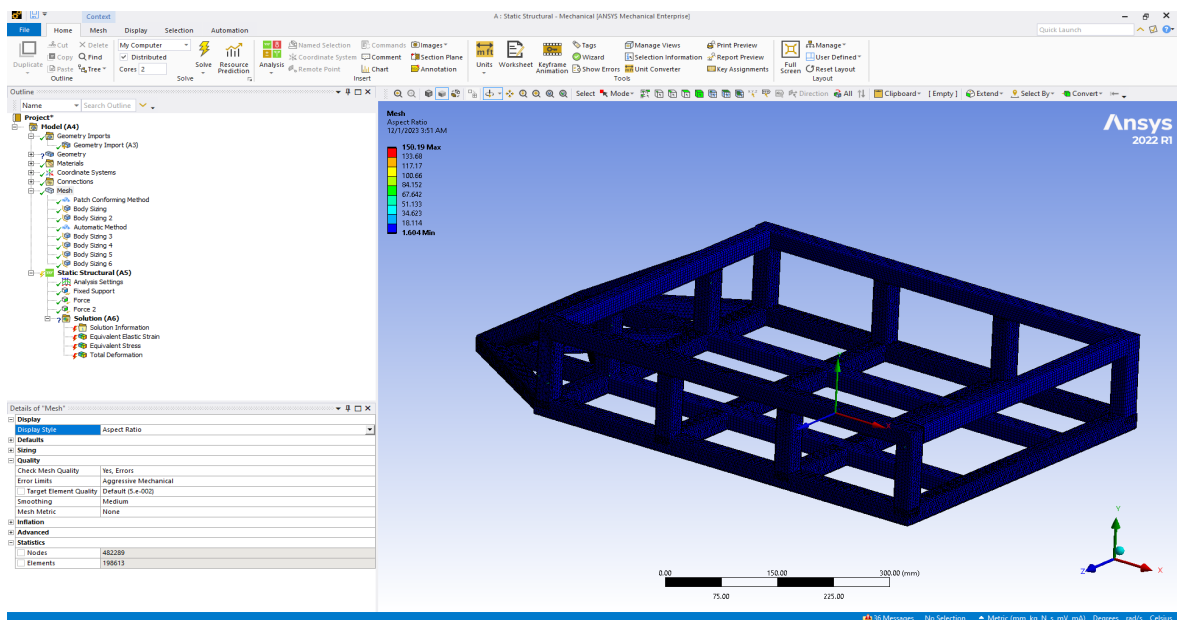

Controls

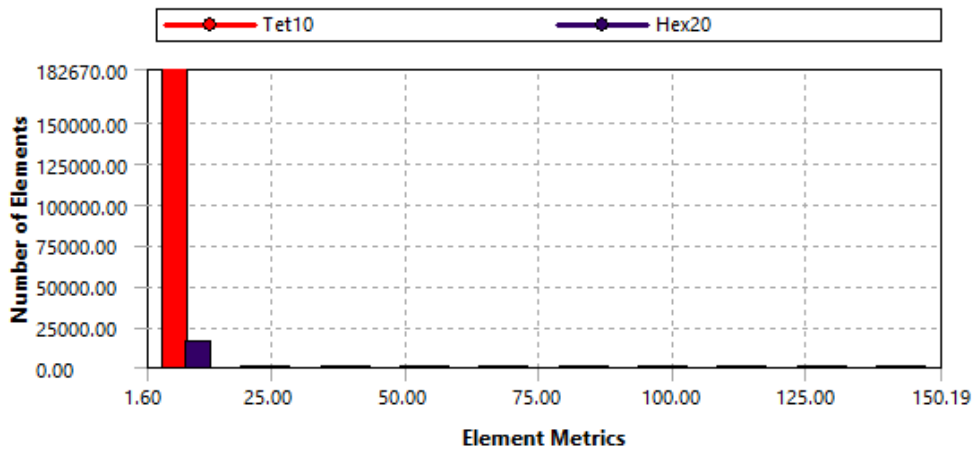

### Element Quality:

The element quality metrics exhibited variations across the mesh, with a minimum value of  $1.9786e-002$ , a maximum of  $0.90075$ , an average of  $0.31163$ , and a standard deviation of  $8.2418e-002$ .

Controls

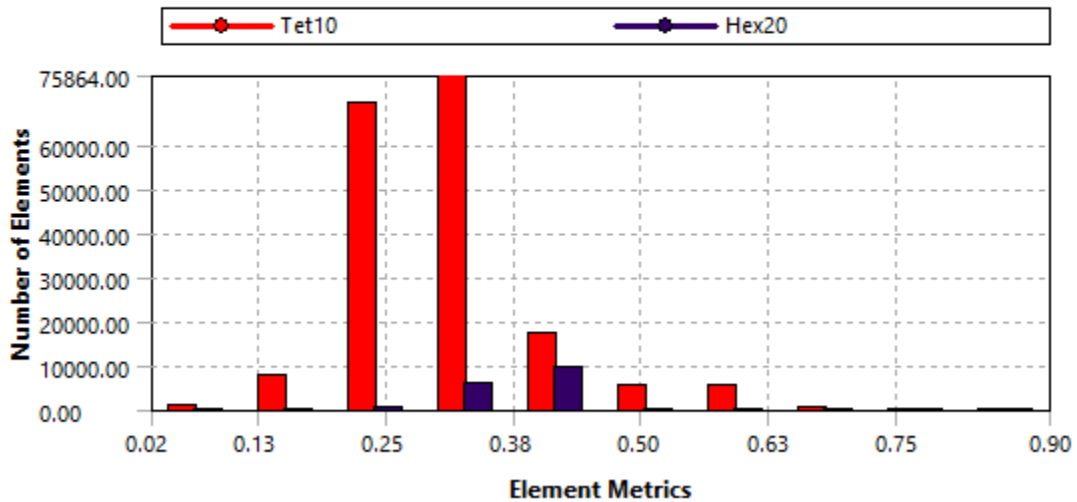

Fig; Number of element vs Element quality graph

### Skewness:

Skewness values ranged from a minimum of  $1.3057e-010$  to a maximum of  $0.99998$ , with an average skewness of  $0.71124$  and a standard deviation of  $0.19267$ .

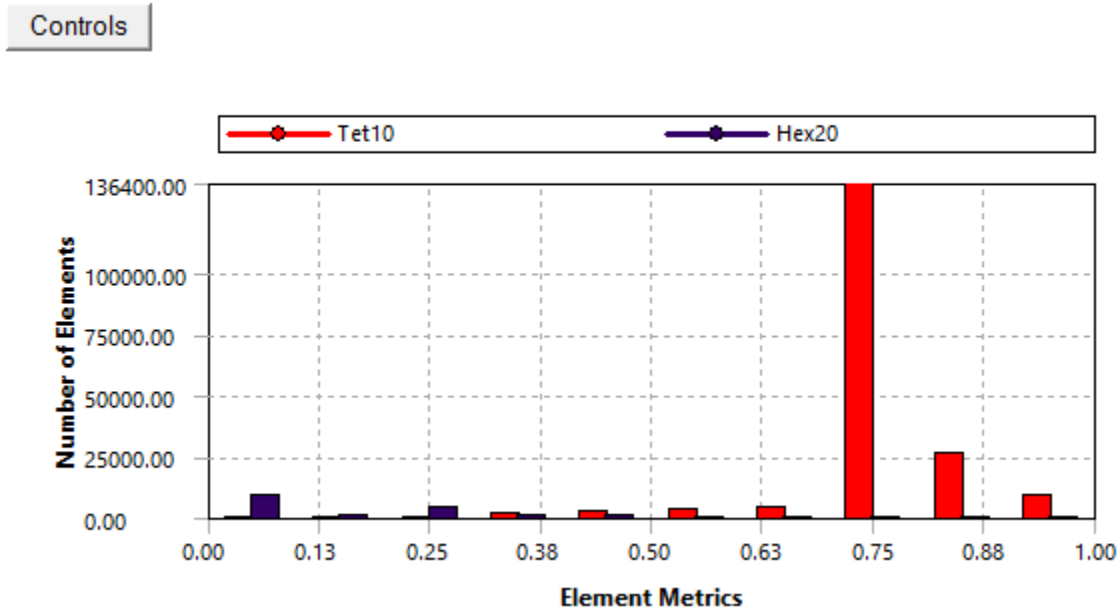
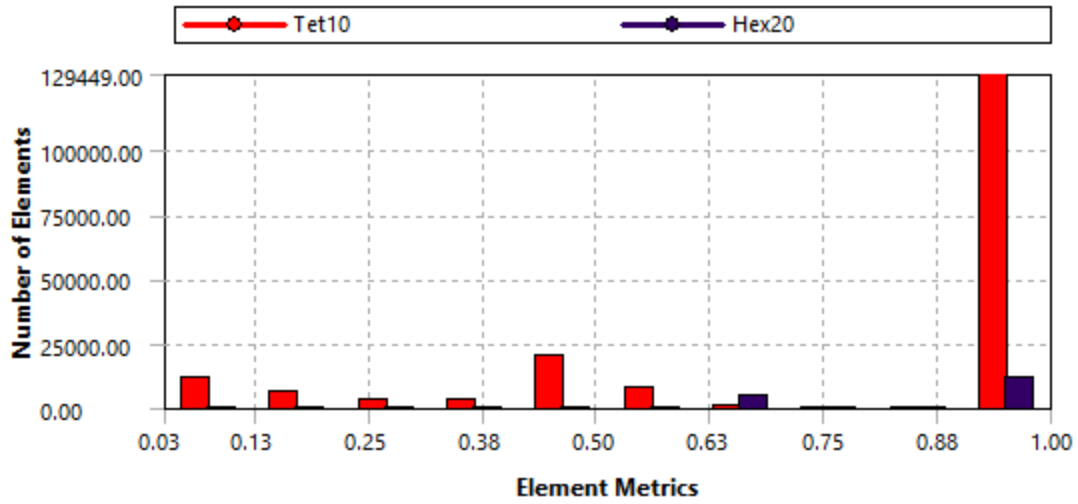

Fig: Number of elements vs skewness graph

### Jacobian Ratios (Corner Nodes and Gauss Point):

Corner nodes' Jacobian ratios varied from a minimum of  $2.5069e-002$  to a maximum of  $1$ , with an average of  $0.81779$  and a standard deviation of  $0.30464$ . Gauss point Jacobian ratios exhibited a minimum of  $0.27475$ , a maximum of  $1$ , an average of  $0.89456$ , and a standard deviation of  $0.17959$ .

Controls



(a)

Controls

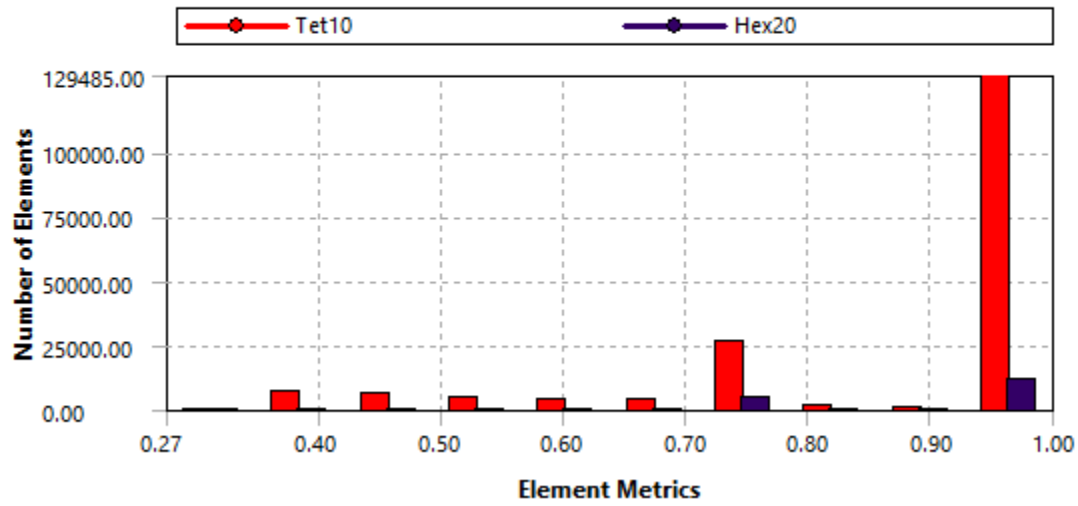

(b)

Fig: Number of elements vs Jacobian values ( a- corner nodes, b- gauss points)

### **Convergence Information:**

The final mesh comprised a total of 482,289 nodes and 198,613 elements. The convergence of the simulation was achieved with this mesh configuration.

### **Results of Mesh Quality Checks:**

During the initial stages, mesh quality was suboptimal, and six members failed during meshing. To address this, an automatic meshing method was applied to the problematic members, setting the element size to 5 mm. This led to significant improvements in mesh quality, especially with the utilization of tetrahedral and hex dominant elements. Notably, inflation was strategically employed in critical areas to enhance the simulation's accuracy.

### **Mesh review:**

The mesh quality for the rover chassis structural analysis appears to be generally well-managed with careful consideration of key parameters. The aspect ratio, with a maximum value of 150.19 and an average of 5.6045, suggests a reasonable distribution of element shapes, avoiding excessive stretching or distortion. The element quality metrics, with an average of 0.31163 and a standard deviation of 8.2418e-002, indicate a balanced quality across the mesh.

The skewness values, with an average of 0.71124 and a standard deviation of 0.19267, reflect a moderate level of skewness but within acceptable limits. The Jacobian ratios for both corner nodes and Gauss points show an average above 0.8, indicating a well-formed mesh with minimal element distortion.

The convergence information further supports the adequacy of the mesh, as the simulation successfully converged with a total of 482,289 nodes and 198,613 elements. Despite initial challenges with mesh quality in specific members, the adaptive strategy of applying automatic meshing and refining the element size to 5 mm demonstrates a proactive approach to addressing issues. The utilization of both tetrahedral and hex dominant elements, along with inflation in critical areas, has contributed to notable improvements in mesh quality and simulation results.

In summary, the mesh quality for the rover chassis structural analysis is commendable, considering the complexity of the design objectives. The chosen mesh parameters, along with the refinement strategies, have resulted in a mesh that aligns well with the simulation goals and produces reliable outcomes.

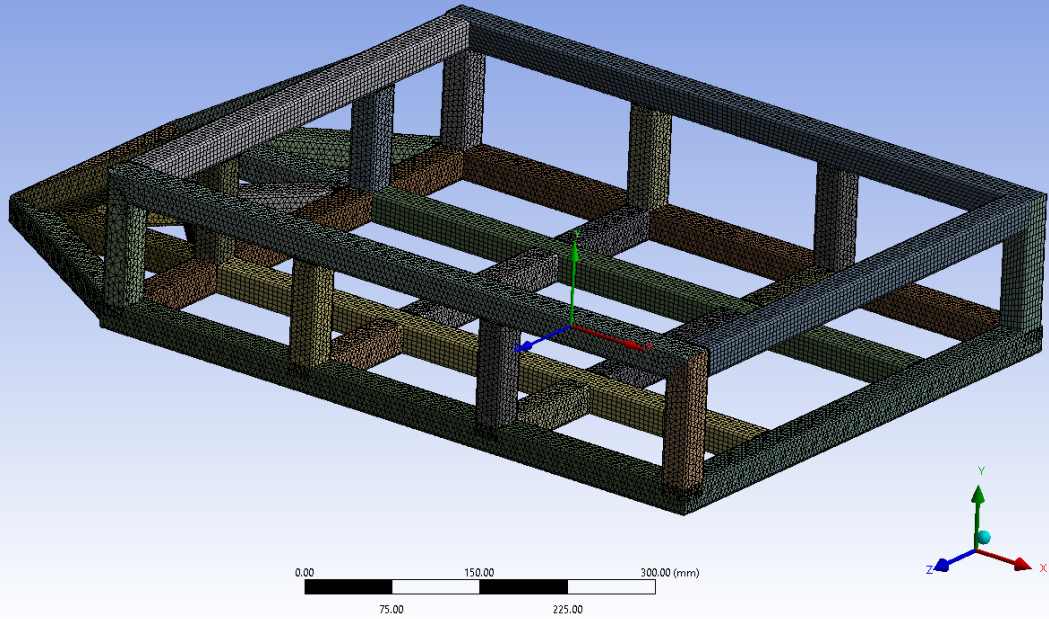

**Fig:** Final mesh

# Deformation Analysis:

## For Stainless Steel Body-

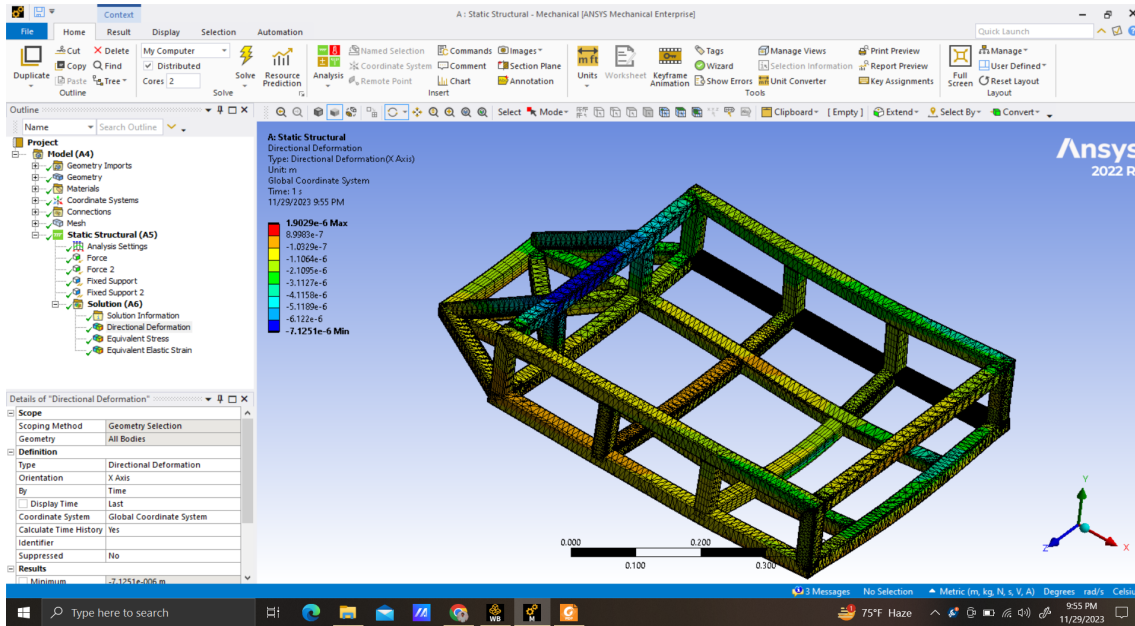

1. The maximum and minimum deformation result for the simulation is .0019029 mm and 0.0071251mm respectively with an average value of 0.004514 mm.

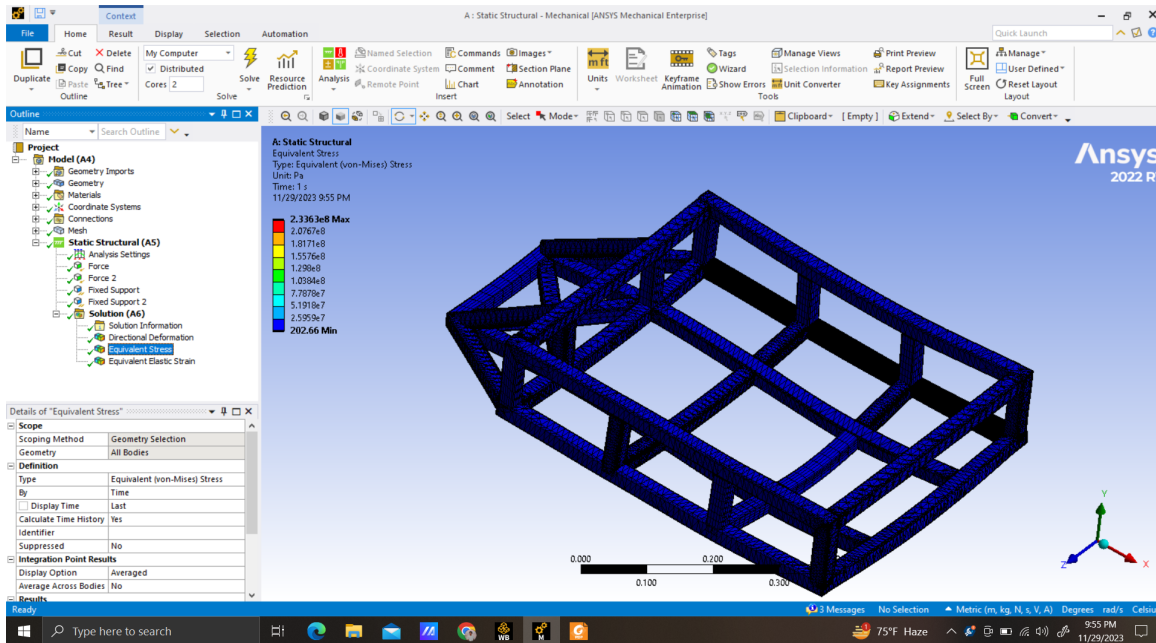

2. The maximum equivalent stress came up to 233.6 MPa whereas the minimum equivalent stress is 0.00020266 MPa. Here, the average value is 103.84 MPa.

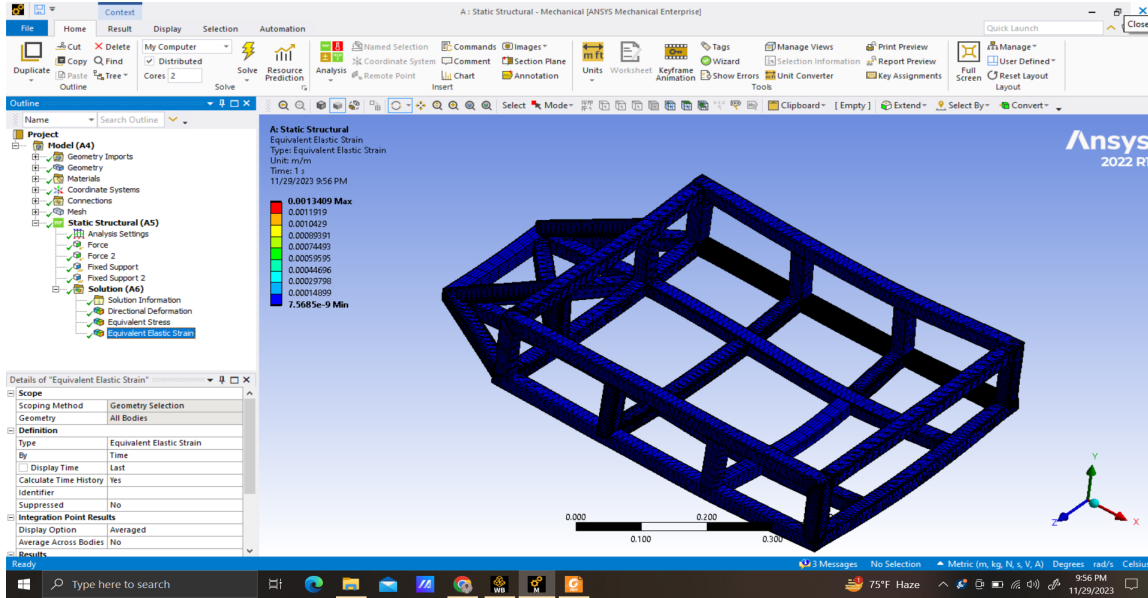

3. The maximum equivalent strain is 0.00013409 and the minimum equivalent strain is 7.5685e-9 with an average value is 0.00059595

### For Aluminium Body-

4. The maximum and minimum deformation result for the simulation is 0.041944mm and 0mm respectively with an average value of 0.011564mm.

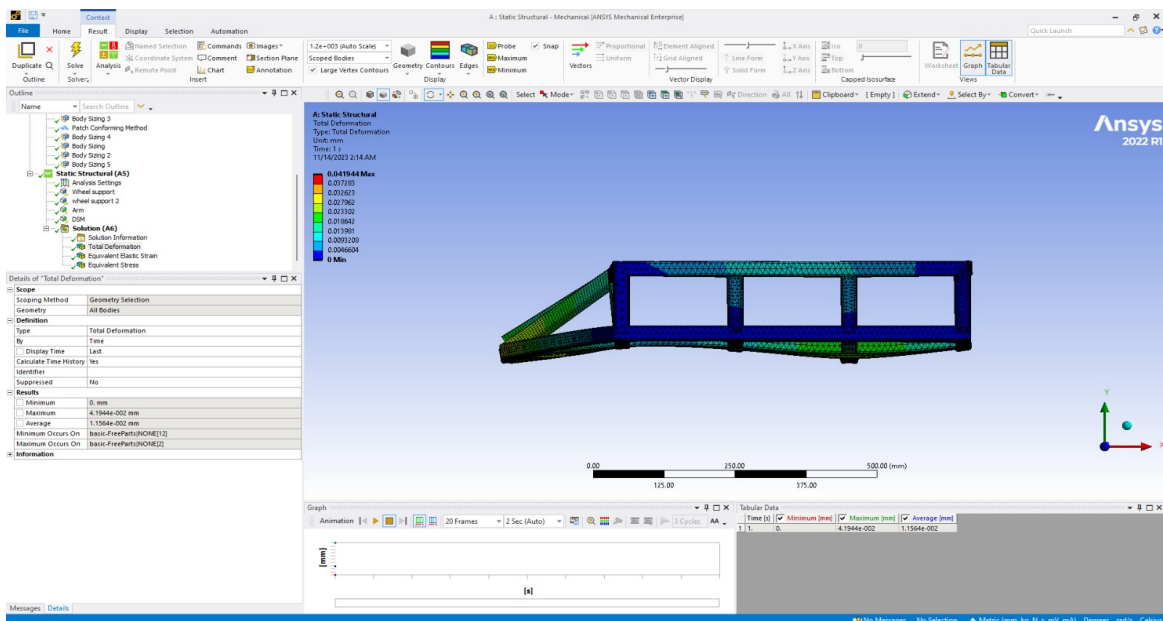
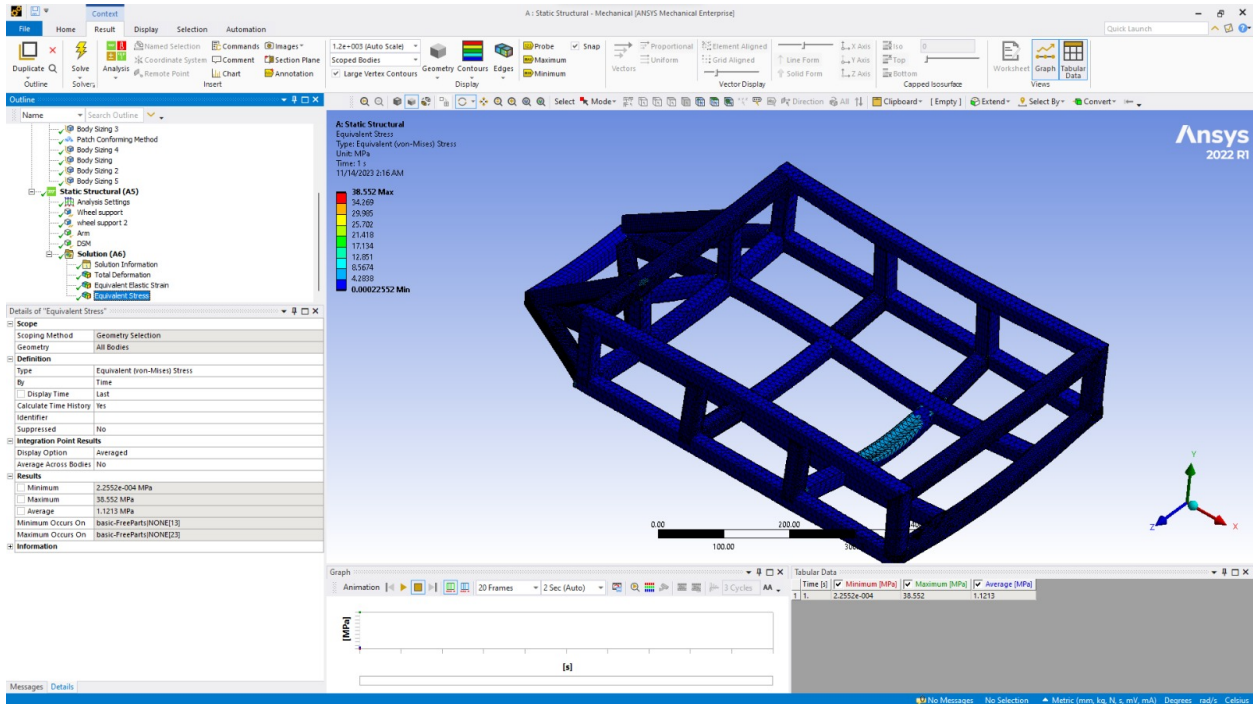
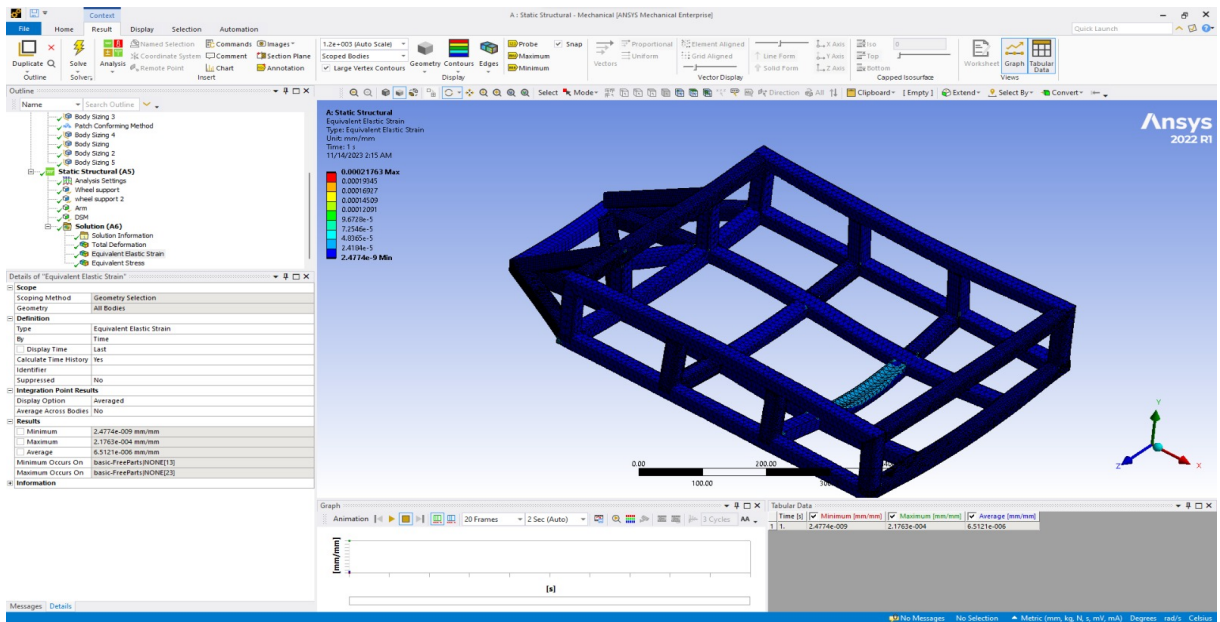

Fig : Total deformation

5. The maximum equivalent stress came up to 38.522MPa whereas the minimum equivalent stress is 0.00022552 MPa. Here, the average value is 1.1213 MPa.



6. Maximum equivalent strain is 0.00021763 and minimum equivalent strain is 2.4774e-9 with an average value of 6.5121e-006



## Comparison:

Property	Stainless Steel (SS)	Aluminum
Total Deformation	Max : .0019029 mm	Max : 0.041944mm
	Average : 0.004514 mm	Average : 0.011564mm
Equivalent Stress	Max : 233.6 MPa	Max :38.522 MPa
	Min :0.00020266 MPa	Min : 0.00022552 MPa
	Average : 103.84 MPa	Average : 1.1213 MPa
Equivalent Strain	Max : 0.00013409	Max : 0.00021763
	Min : 7.5685e-9	Min : 2.4774e-9
	Average : 0.00059595	Average : 6.5121e-006

From the data plotted in the table above, it can be seen that the SS material is comparatively more durable than Aluminum. Although the equivalent stress developed in Aluminum is lower than that of Stainless Steel, the total deformation of the latter is lower. This indicates that for the same design, Stainless Steel can be considered stronger. The only drawback of using SS over aluminum might be the weight being significantly higher.

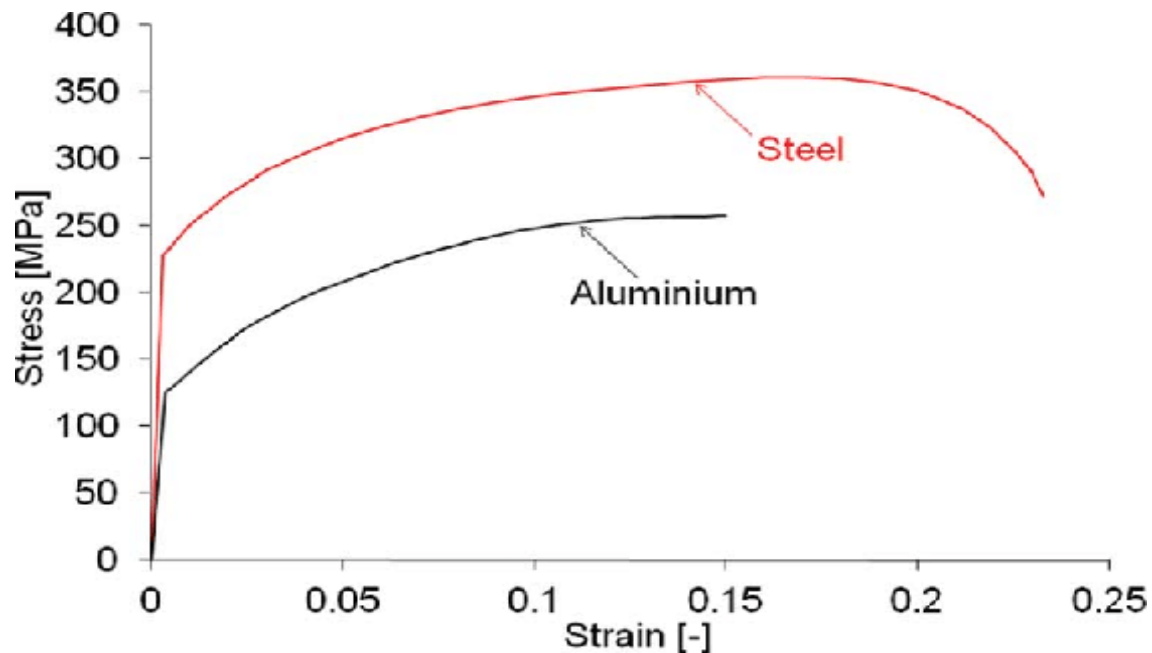

## **Conclusion:**

This project aims to study the structural design of a rover chassis, in order to use its analytical results to reconstruct an improved structure according to the standards of engineering design and international space institutions.

The main goal of our project was preparation of the simulation environment to test special rover design. We compared two different approaches of simulation of the model and we got similar results. This proves we have properly set simulation models of the rover. Key factor of the simulation model is the combination of bindings representing joints. Simulation binding definitions vary in different software and many combinations had to be tested to achieve the right behavior of the model. The center of mass was determined and all the components were placed on the chassis accordingly.

The improvised design of this Mars exploration rover chassis has been made for quick and easy maneuvering of the rover under challenging terrains without compromising its stability.

The report consists of static analysis of rover chassis, which deformation, stress and strain follows the same pattern as per the paper "An Advanced Spider-Like Rocker-Bogie Suspension System for Mars Exploration Rovers". The simulation shows results that match the deformation and other properties region of action. So, the study shows that our suitcase size rover chassis is efficient to manufacture and serves our interest.

The project outcome is hereby successfully delivered.

## **Reference:**

1. <https://www.researchgate.net/publication/305080946> **An Advanced Spider-Like Rocker-Bogie Suspension System for Mars Exploration Rovers**
2. <https://researchgate.net/publication/313543991> **6 Wheeled Mars rover design for terrain traversing equipment servicing astronaut assistance and on-board testing**
3. <https://mars.nasa.gov/mars2020/spacecraft/rover/body/>
4. <https://ieeexplore.ieee.org/document/9265497>
5. <https://www.rmg.co.uk/stories/topics/mars-nasa-rover-perseverance>
6. <https://www.researchgate.net/publication/341591144> **A comparative study of 5083 aluminium alloy and 316L stainless steel for ship building material**
7. <https://ieeexplore.ieee.org/document/10211927/>
8. <https://www.science.gov/topicpages/a/analysis+software+ansys>