



**stravilink**

by CDM Stravitec

**WALL & CEILING ELASTIC DECOUPLING**  
SOLUTIONS FOR SUPERIOR ACOUSTIC PERFORMANCE

# CDM Stravitec, Your Acoustical Wall & Ceiling Partner

Stravilink by CDM Stravitec offers a wide range of wall and ceiling acoustical decoupling solutions for virtually any performance requirement and void scenario.

- Delivered at competitive prices
- With world-class technical support
- Readily available solutions

With a global presence and local highly trained teams, we're always nearby to deliver expert support wherever sound control matters most.



## DOCUMENTATION

- Installation manuals
- Typical cross sections
- Detailed technical datasheets
- Acoustical test reports
- Shop drawings for more complex projects
- Declaration of performance



## TECHNICAL SUPPORT

- Local technical sales team for appropriate solution recommendations
- Dedicated Project Delivery Managers for details and logistics and coordination of timeline & deliveries
- Design Engineers and on site supervision for complex installations



## WIDE RANGE OF SOLUTIONS

- For all soffits and acoustical criteria
- For all mounting, interface, and for different loads
- Possibility to tailor solutions according to project requirements

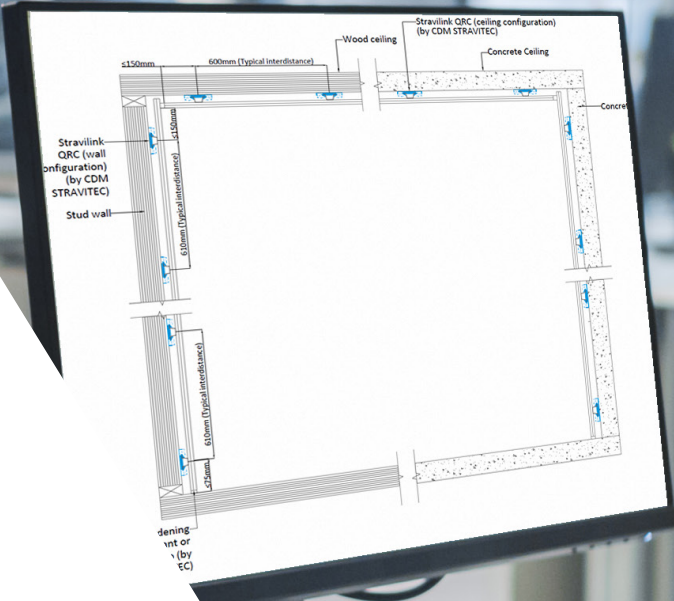

### Q&E Management

CDM Stravitec nv operates ISO 9001:2015 and ISO 14001:2015 approved quality and environmental management systems.



**Design for Disassembly**

The traditional model of "Build-Use-Demolish" is slowly succeeded by the concept "Design for disassembly". The objective being to adopt "design with foresight" decisions to facilitate repurposing, retrofitting, reducing waste and extending lifespans.

Most of Stravilink solutions are developed with this objective in mind.

# Box-in-Box

## Isolated Ceilings, Walls & Floors

A box-in-box system (sometimes called a room-within-a-room) is a construction method used to achieve high levels of sound isolation. It's commonly applied in recording studios, home theatres, concert halls, or any environment where external noise must be kept out and/or internal noise kept in.

It consists of an inner "box" (room) structurally isolated from an outer "box" (the existing building shell). The inner walls, ceiling, and floor are physically decoupled from the outer structure.

The main objective of this concept is to:

- Reduce the flanking paths for sound transmission
- Increase the sound isolation between spaces

A box-in-box system is generally composed of:

- **Isolated Ceiling**
- **Isolated Walls**
  - Generally supported on the floating floor
  - Either a self-supported wall system or with resilient connection (wall ties) to the structural element
- **Floating Floor**

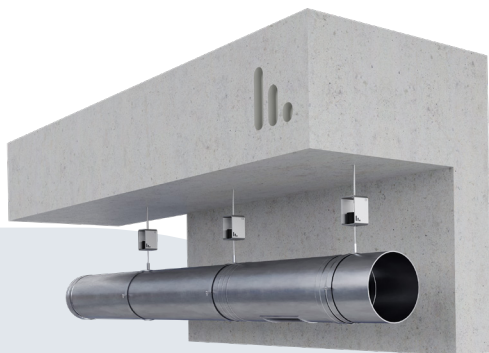

On this brochure you can also find info about **support hangers**, mainly used for heavy duty applications, such as support of mechanical equipment or heavy structures – page 17.



1

**1 Isolated Ceiling Hangers** – page 8 to 11

The **Stravilink** range offers a variety of isolated **ceiling hanger** solutions, featuring elastomeric pads or springs, suitable for all types of soffits, mountings, and interfaces. This flexibility ensures that Stravilink solutions can meet any performance criteria, construction methods, or space constraints.

**2 Wall Isolation** – page 11 to 16

The **Stravilink** range includes **wall clips, sway braces, supports, and fixings** designed to provide complete elastic decoupling of partition walls and lining systems, without compromising structural integrity and while still allowing lateral restraint. The range offers solutions adaptable to a wide variety of wall types, including masonry and stud walls, as well as different support conditions.

2



**3 High Performance Floating Floors**

The **Stravifloor** range comprises both **lightweight and concrete floating floor solutions**, engineered to isolate airborne noise, vibration, and impact noise while ensuring the structural and functional integrity of the entire floor system.

For more about Stravifloor



3

# Stravilink Solutions Overview

## Ceiling Solutions

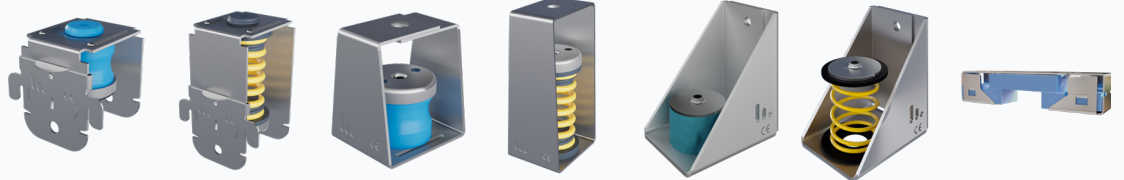

Stravilink  
CC40/60-P

Stravilink  
CC40/60-S

Stravilink  
DCH-P

Stravilink  
DCH-S

Stravilink  
IJH-P

Stravilink  
IJH-S

Stravilink  
QRC

Soffit	Concrete <sup>(1)</sup>	●	●	●	●		●	
	CLT <sup>(2)</sup>	●	●	●	●		●	
	Wood Joist					●	●	●
Mounting	Direct	●	●	●	●	●	●	●
	Rod	●	●	●	●			
	Wire			●	●			
Interface <sup>(3)</sup>	C-Channel	★★★★	★★★★	★	★	★	★	
	MF Grid			★★★★	★★★★	★	★	
	Hat-shaped Channel							★★★★
	Low Void <sup>(4)</sup>	★★	★	★★	★	★★★★	★★★★	★★★★(★)
	Load Range [kg]	10-45	4-59	10-45	4-59	10-53	5-78	24
	Natural Frequency @ADL <sup>(5)</sup> [Hz]	8	4	8	4	12	4	10
	Page	8	8	9	9	10	10	11

<sup>(1)</sup> Including Autoclaved Aerated Concrete (AAC)

<sup>(2)</sup> Cross-Laminated Timber

<sup>(3)</sup> Solutions with higher rank are solutions that are a better fit for this type of interface, while no points means it is not compatible

<sup>(4)</sup> Solutions with higher rank are solutions allowing for the lowest build-up

<sup>(5)</sup> Acoustical Design Load

## Wall Solutions

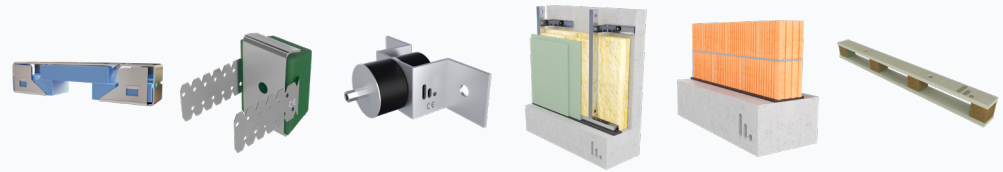

		Stravilink QRC	Stravilink QR	Stravilink WH	Stravilink WallFix	Stravilink WallStrip	Stravilink WallBatten
Drywall Systems	Partition Wall	●			●	●	
	Lining Wall	●	●	●	●		●
Wall Construction	Metal Stud Wall	●	●	●	●		
	Wood Stud Wall		●				●
	Masonry Wall			●		●	
Solution Type	Sway Brace	●	●	●			●
	Support				●	●	
Page		11	12	13	14	15	16

## Support Solutions



Stravilink ISH-P



Stravilink ISH-S

Load Range [kg]	30 – 280	24 – 316
Natural Frequency @ADL <sup>(1)</sup> [Hz]	8	4
Page	17	17

<sup>(1)</sup> Acoustical Design Load

# Stravilink CC40/60-P/S

Channel Clip with Elastomeric Pads or Springs

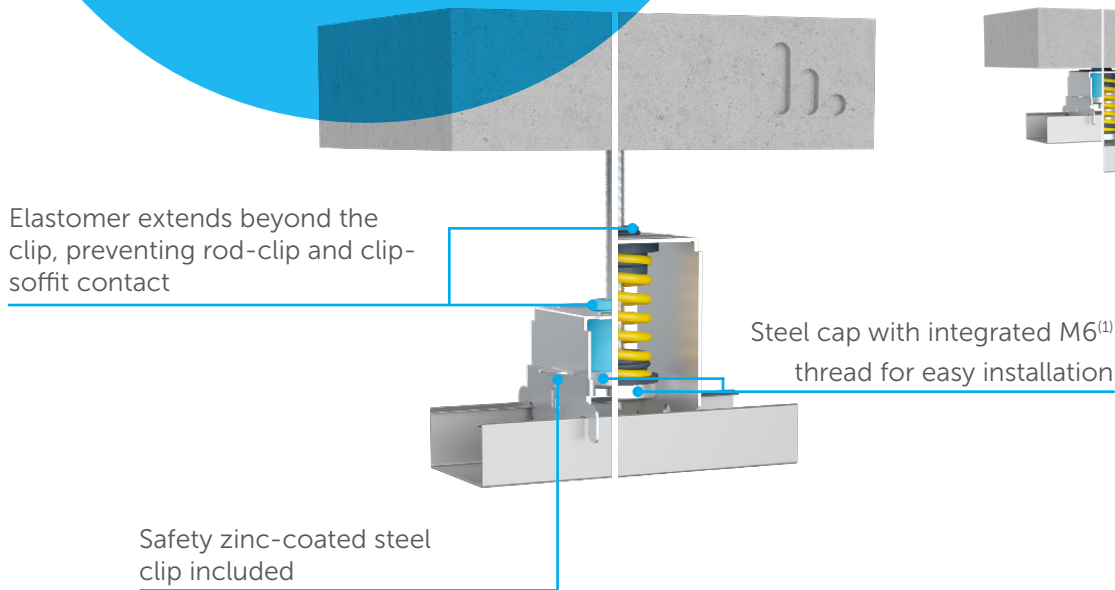

OTHER POSSIBLE MOUNTINGS & INTERFACES:

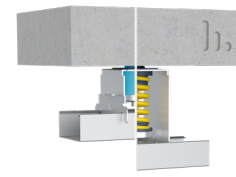

For larger renders, visit online solution page

Soffit types:



## Stravilink CC 40/60-P/S

Channel Clips with Elastomeric Pads or Springs, specifically designed for suspending acoustic ceilings. They are compatible with 47 mm and 60 mm steel ceiling channels, respectively, and help optimize sound insulation between vertically stacked rooms.

	Stravilink CC40-P	Stravilink CC60-P	Stravilink CC40-S	Stravilink CC60-S
Load Range [kg]	10-45	10-45	4-59	4-59
Natural Frequency @ADL <sup>(2)</sup> [Hz]	8	8	4	4
Min. Void Depth [mm]	65	74	97	106

<sup>(1)</sup> Available in M8 upon request <sup>(2)</sup> Acoustical Design Load



## MAIN BENEFITS

### Guaranteed Acoustical Performance

Elastomeric pad extends beyond the metal clip, ensuring optimal acoustical separation and avoiding any short-circuiting.

### Safety & Structural Integrity

Built-in safety clip prevents ceiling channel deformation under excess loads.

### Flexible Design

Flexible void options for limited space or increased performance.



### Time & Labour Savings

Simple, intuitive snap-in system makes the process straightforward.

### Installation Ease

Designed for a quick assembly of 47 mm and 60 mm steel ceiling channels.

Colour-coded pads and springs for easy load ID onsite: right colour, no mistake.

Threaded steel pad cap - installation without a nut.

# Stravilink DCH-P/S

## Drop Ceiling Hanger with Elastomeric Pads or Springs

### OTHER POSSIBLE MOUNTINGS & INTERFACES:

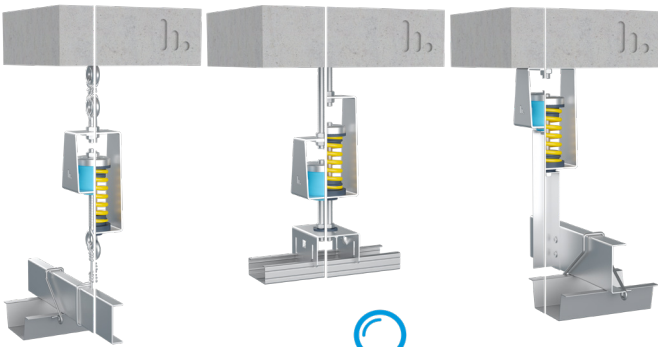

For larger renders, visit online solution page

Colour-coded springs and elastomeric pads for easy verification on site

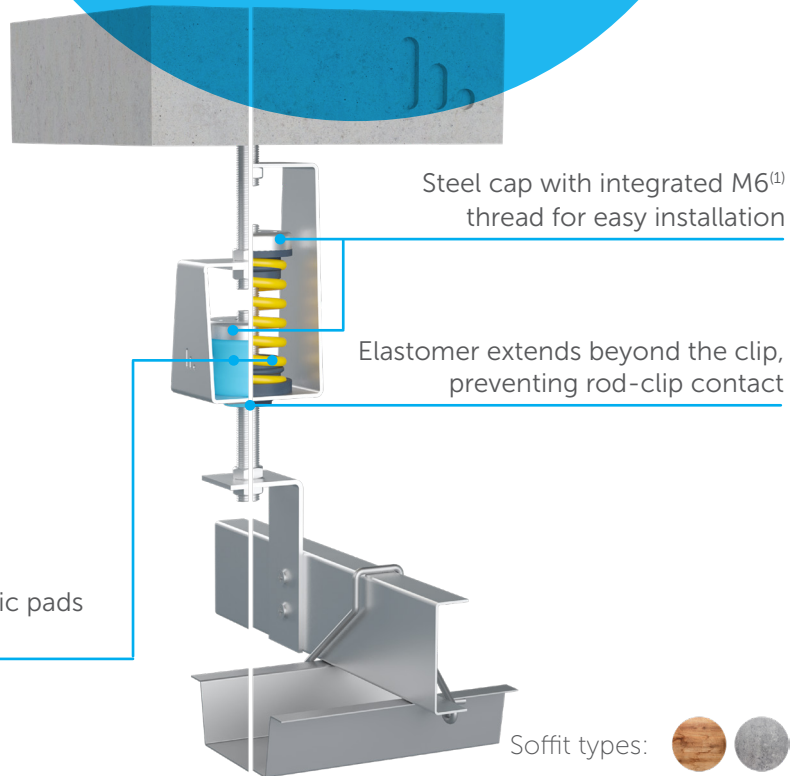

### Stravilink DCH-P/-S

Drop Ceiling Hanger with Elastomeric Pads or Springs, designed to fit most ceiling voids and seamlessly integrate with all ceiling types. It enhances sound insulation between vertically stacked rooms, ensuring optimal acoustic performance.

#### Stravilink DCH-P

#### Stravilink DCH-S

	Stravilink DCH-P	Stravilink DCH-S
Load Range [kg]	10-45	4-59
Natural Frequency @ADL <sup>(2)</sup> [Hz]	8	4
Frame Height [mm]	62.8	104

<sup>(1)</sup> Available in M8 upon request <sup>(2)</sup> Acoustical Design Load



## MAIN BENEFITS



#### Guaranteed Acoustical Performance

Elastomeric pad extends beyond the metal clip, avoiding any short-circuiting.

#### Flexible Design

Flexible void options, for limited space or increased performance.

#### Easy to Specify

Ready-to-use .dwg cross-sections available online. CE marked solution, fulfilling high safety and environmental protection requirements.

#### Time & Labour Savings

Only two components.

#### Installation Ease

Colour-coded pads or springs for easy load ID onsite: right colour, no mistake. Threaded steel pad cap - installation without a nut.

#### Versatility

Use your preferred interface (C-Channel, MF grid, etc).

Use your preferred mounting method (direct mounting, rod suspension or wire suspension).

# Stravilink IJH-P/S

Isolation Joist Hanger with Elastomeric Pads or Springs

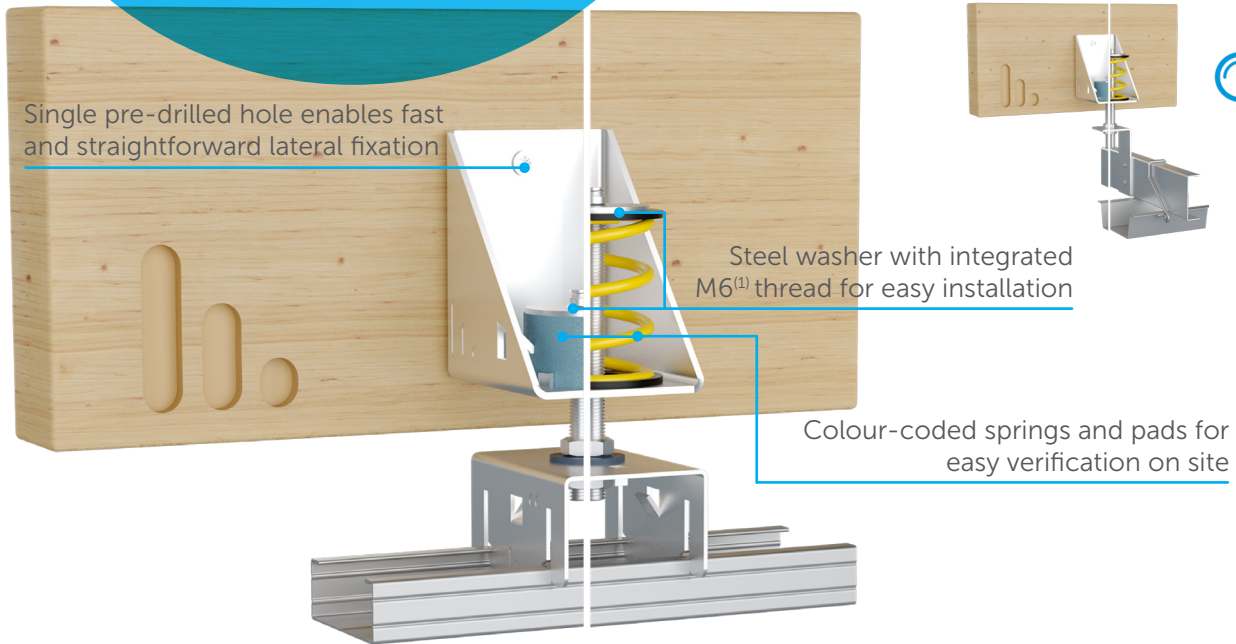

OTHER POSSIBLE INTERFACES:



For larger renders, visit online solution page

Soffit types:



## Stravilink IJH-P/S

Isolation **J**oist **H**anger with Elastomeric **P**ads or **S**prings, designed to support suspended ceiling systems of joist structural floors, optimizing sound insulation between vertically stacked rooms.

	Stravilink IJH-P	Stravilink IJH-S
Load Range [kg]	10-53	5-78
Natural Frequency @ADL <sup>(2)</sup> [Hz]	12	4
Frame Height [mm]	73	73

<sup>(1)</sup> Available in M8, upon request <sup>(2)</sup> Acoustical Design Load



## MAIN BENEFITS



### Guaranteed Acoustical Performance

Guaranteed performance on historical, existing or new wooden joist timber buildings.

### Flexible Design

Space-saving option where boards can be almost immediately below the wood joist. Flexible void options, for limited space or increased performance.

### Easy to Specify

CE marked solution, fulfilling high safety and environmental protection requirements.

### Time & Labour Savings

Create flat ceilings regardless of structure conditions with the variable hanging height option.

### Installation Ease

Pre-drilled, single-attachment installation method. Ideal for lateral attachment.

Colour-coded pads and springs for easy load ID onsite: right colour, no mistake.

Threaded washer - installation without a nut.

### Versatility

Use your preferred interface (C-Channel, MF grid, etc.).

# Stravilink QRC

## Quiet Resilient Clip

### OTHER POSSIBLE SUPPORTS:

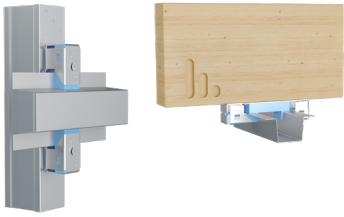

For larger renders, visit online solution page

Clearance hole of 5 mm for 2 screws fixation

Safety for over-compression

Self-adhesive strip for initial placement

For hat-shaped channel widths from 60-70 mm

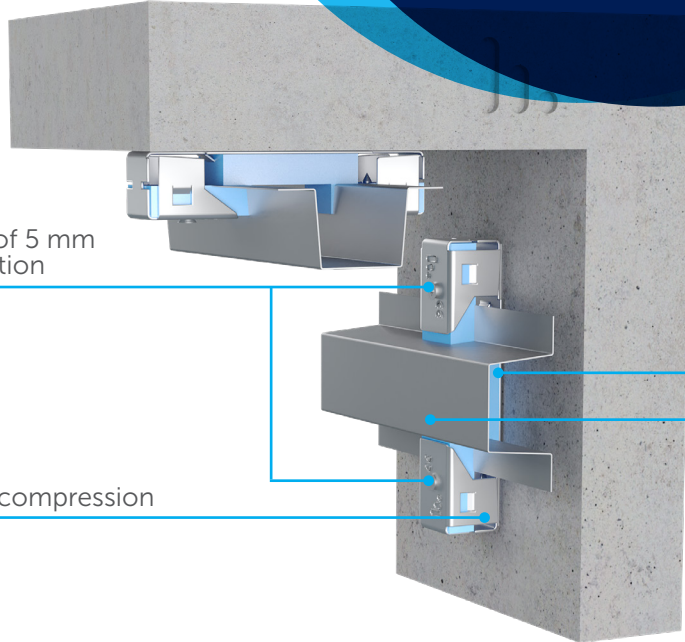

Soffit types:



## Stravilink QRC

Quiet Resilient Clip, a slim isolated wall and ceiling clip designed to isolate a standard wall and ceiling hat-shaped channel, therefore optimizing sound insulation between horizontally and vertically arranged rooms.

### Stravilink QRC

Load Range [kg]	Ceiling: $\leq 24$ Wall: $\leq 27$
Natural Frequency @ADL <sup>(1)</sup> [Hz]	10
Void Height [mm]	41 <sup>(2)</sup>

<sup>(1)</sup> Acoustical Design Load <sup>(2)</sup> 44 before precompression



## MAIN BENEFITS



### Guaranteed Acoustical Performance

Supports up to 24 kg with a 10 Hz natural frequency at design load (ceiling applications).

### Safety & Structural Integrity

Prevents isolated partition buckling with added structural stability.

Made with an electrogalvanized flexible steel element for guaranteed long-term performance.

### Space Efficiency

Appropriate solution for renovations of older buildings and adaptive reuse, with low-profile void as low as 41 mm for both ceiling and wall applications.

### Time & Labour Savings

Attaches to substrate with two pre-drilled 5 mm attachment points. Use the self-adhesion strip for easy placement.

One-component system to attach the hat-shaped channels.

Over-compression safety eliminates the risk of over-compression installation errors.

### Versatility

Versatile solution attaches to ceilings or walls, and any substrate. Appropriate for retrofit projects with narrow voids.

# Stravilink QR

## Acoustical Brackets for Quiet Rooms

Zinc-plated and pre-drilled strips



OTHER POSSIBLE STUDS:



For larger renders, visit online solution page

Integrated system for controlled compression

Zinc-plated frame with hole for direct fixing to support

### Stravilink QR

Specifically designed for lining systems, Stravilink QR acoustic brackets are engineered to acoustically isolate wall linings from the base structure, significantly enhancing the overall sound performance of the complete wall assembly.

#### Stravilink QR

Load Range [kg]	Up to 16
Natural Frequency @ADL <sup>(1)</sup> [Hz]	≤ 14
Min. Distance Between the Support Wall and Vertical Profile [mm]	30

<sup>(1)</sup> Acoustical Design Load



### MAIN BENEFITS



#### Safety & Structural Integrity

Prevents isolated partition buckling with added structural stability.

Made with zinc-plated steel for guaranteed long-term performance.

#### Flexible Design

Flexible void options starting from 30 mm between the stud and the supporting wall.

#### Easy To Specify

Easily integrate into project documentation and workflows.

#### Time & Labour Savings

Pre-assembled, single-piece solution.

Over-compression safety eliminates the risk of over-compression installation errors.

Attaches to substrate with one attachment point. Strips are easily bent and attached to partitions to any stud width with pre-drilled holes.

# Stravilink WH

## Resilient Wall Sway Brace

OTHER POSSIBLE WALLS:



For larger renders, visit online solution page

Two holes for direct fixing

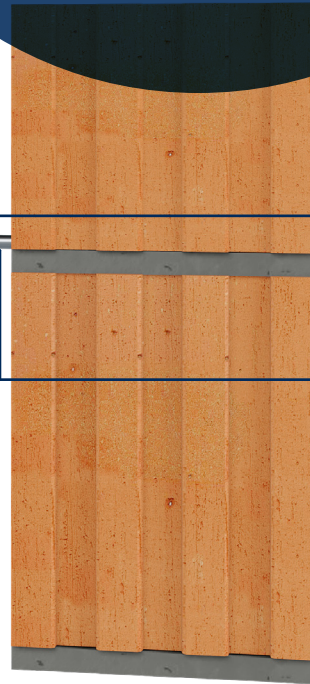
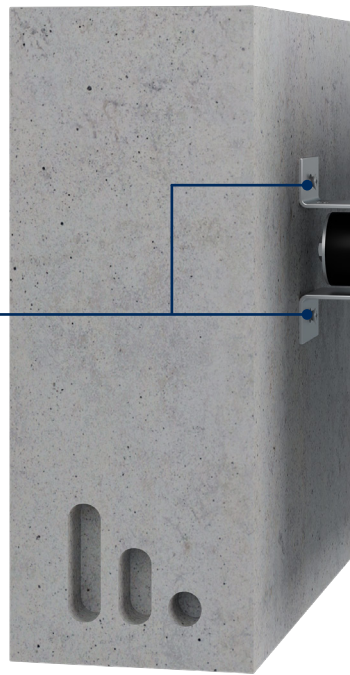

Pre-compressed elastomer to ensure consistent acoustical isolation

Coupling nut to fit bolt or hooked end, for all types of walls

### Stravilink WH

Resilient sway brace, enabling walls to be mechanically tied together without rigidly connecting them. Walls can be either stud walls (via bolt end) or masonry block walls (via hooked end).

#### Stravilink WH

Load Range [kg]	Up to 65
Natural Frequency @ADL <sup>(1)</sup> [Hz]	10
Min. Void Depth [mm]	Stud Wall: 120 <sup>(2)</sup> Masonry Wall: 70

<sup>(1)</sup> Acoustical Design Load <sup>(2)</sup> Using metal C-stud of 50 mm wide



#### Safety & Structural Integrity

Prevents isolated partition buckling with added structural stability.

Made with zinc-plated steel for guaranteed long-term performance.

#### Flexible Design

Flexible void options starting from 70 mm between the stud or masonry wall and the supporting wall.



### MAIN BENEFITS

#### Time & Labour Savings

Can be installed with an unskilled labour force. Pre-assembled, single-piece solution.

#### Flexible Design

Easy inventory management. Installs on both wood stud and masonry walls.

# Stravilink WallFix

## Stud Base Isolation & Fixation

DOUBLE WALL:    ACCESSORY:



Stravilink RHD  
(Resilient Head Detail)



For larger renders, visit online solution page

Stravilink WallFix Washer supplied with pre-drilled hole and integrated metal washer for easy installation

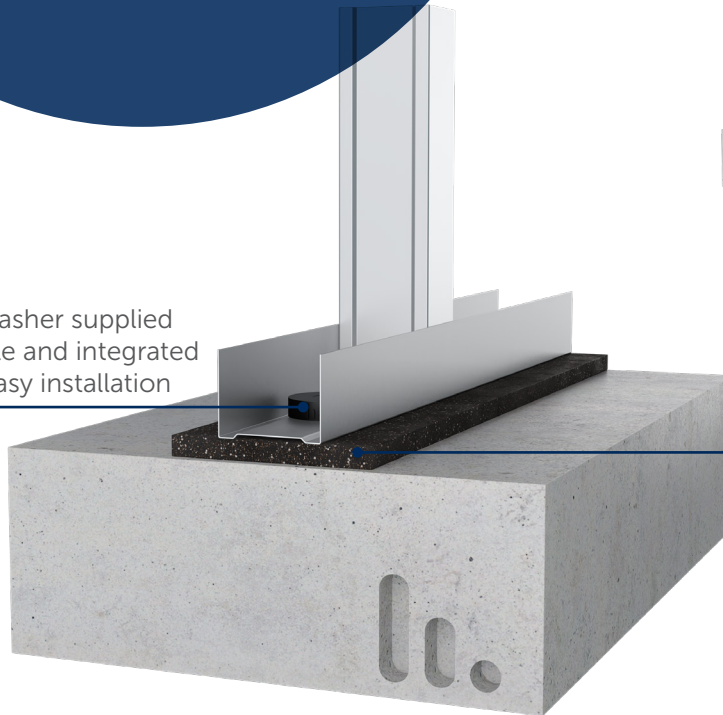

Stravilink WallFix Strip, easy to cut and available in various widths to suit different wall widths

### Stravilink WallFix

Sound-insulating system for partition and lining walls. It uses strips under metal runners and washers to fix runners to floors or ceilings. The optional Stravilink WallFix Bracket further decouples the lining wall from the structure.

#### Stravilink WallFix

Maximum Load [kg/lm]	2,000 <sup>[1]</sup>
Deflection [mm]	< 2
Typical Metal Stud Runners [mm]	48, 50, 72, 100, 150

<sup>[1]</sup> Depending on the track footprint, value for track of 100 mm



#### Guaranteed Performance

Reliable long-term performance thanks to the use of materials with minimal creep.

Provides structural integrity without compromising vibration and noise isolation.

#### Flexible Design

Different strip widths available, to suit any cavity width. High load capacity, to suit to different load conditions.

#### Sustainability

Using agglomerated rubber strips with more than 90% recycled content.

### MAIN BENEFITS



#### Installation Ease

Two-component system includes elastomeric washers with an integrated metal washer for simple attachment and elastomeric strips. Elastomeric strips in rolls - easy to handle, transport, and cut on-site.

Full support of metal stud runners by unrolling the strip, without complexity in positioning.

Elastomeric strips are available in the widths of most metal studs, making integration easy without custom cutting.

# Stravilink WallStrip

Load Bearing Resilient Strip

ACCESSORY:



Stravilink RHD  
(Resilient Head Detail)



For larger renders, visit online solution page

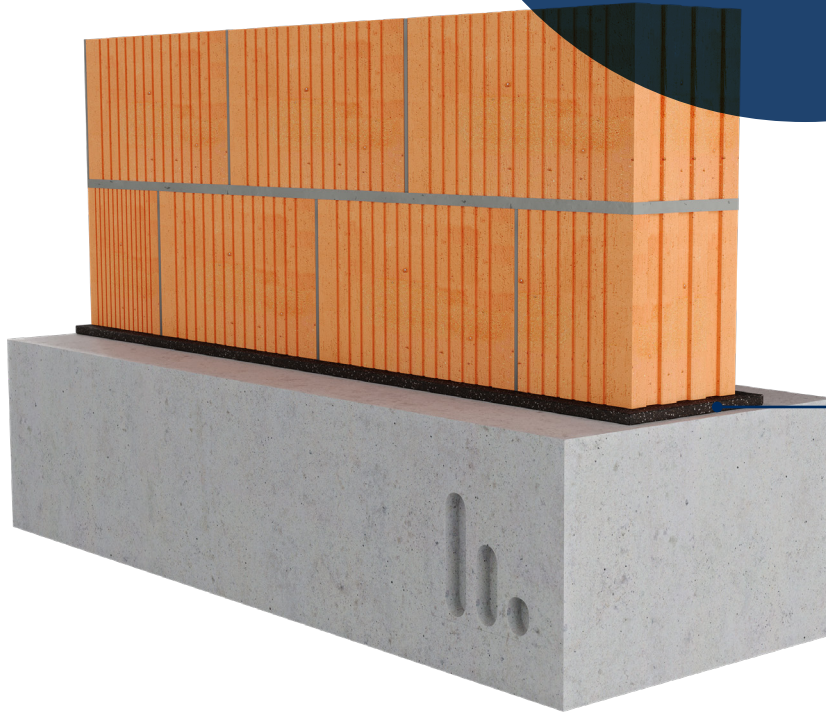

Elastomeric strip available in various widths

## Stravilink WallStrip

Resilient strip specifically designed to reduce flanking transmissions in load-bearing walls, enhancing both vibration and structural noise isolation by limiting unwanted noise transfer throughout the building.

### Stravilink WallStrip

Maximum Load [kg/lm]	2,600 <sup>[1]</sup>
Deflection [mm]	< 2
Typical Standard Strip Width [mm]	130, 200

<sup>[1]</sup> Depending on the wall footprint, value for 130 mm walls



### Guaranteed Performance

Reliable long-term performance thanks to the use of materials with minimal creep.

Provides structural integrity without compromising vibration and noise isolation

### Flexible Design

Different strip widths available, to suit any cavity width.

High load capacity, to suit to different load conditions.

### Sustainability

Using agglomerated rubber with more than 90% recycled content.



## MAIN BENEFITS

### Time & Labour Savings

Building walls directly onto the strip without the need for other attachments saves time on-site.

### Installation Ease

Streamlined solution is fast and easy to install, easy to handle, transport, and cut on-site.

Available to accommodate most masonry wall widths, eliminating the need for custom widths.

# Stravilink WallBatten

## Stud Base Isolation & Fixation



### Stravilink WallBatten

Resilient timber batten that acoustically isolates dry walls from structural elements, reducing structure-borne noise transmission. Supplied as a ready-to-install component, it enables quick and easy installation.

#### Stravilink WallBatten

Load Range [kg]	38 kg/lm
Natural Frequency @ADL <sup>(1)</sup> [Hz]	12
Min. Void Depth [mm]	56

<sup>(1)</sup> Acoustical Design Load



### MAIN BENEFITS



#### Guaranteed Acoustical Performance

Unique high-performance isolation system tested by third parties.

Used in various projects, including box-in-box installations.

No mechanical fixations between the wall parties.

#### Flexible Design

Can support higher-density boards for higher strength requirements.

System available with two different wall thicknesses.

#### Time & Labour Savings

It attaches to the substrate with only two attachment points, and the boards are directly attached to the batten for straightforward installation.

Pre-drilled fixation points in the wooden batten, with different sizes to allow the fixation to the support through the batten.

Pre-assembled, single-piece solution.

No extra components needed.

# Stravilink ISH-P/-S

## Isolation Support Hanger

### OTHER POSSIBLE INTERFACES:

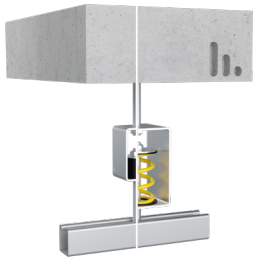

For larger renders, visit online solution page

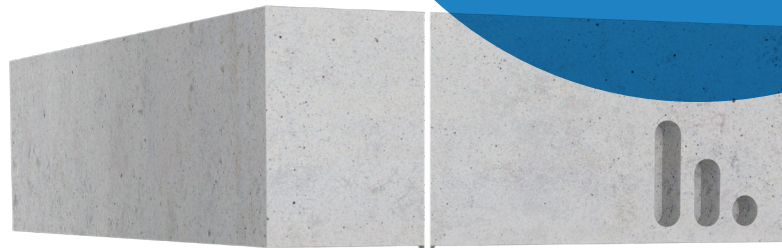

Colour-coded springs and pads for easy verification on site

Robust steel frame able to cope with higher loads

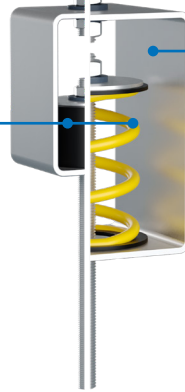

### Stravilink ISH-P/-S

Isolation Support Hanger with elastomeric Pads or Springs, designed to support heavy-duty elements or structures, such as mechanical equipment, ductwork or ceilings with heavier structures, by efficiently handling high suspended loads.

#### Stravilink ISH-P

#### Stravilink ISH-S

	Stravilink ISH-P	Stravilink ISH-S
Load Range [kg]	30 - 280	24 - 316
Natural Frequency @ADL <sup>(1)</sup> [Hz]	8	4
Frame Height [mm]	80	120

<sup>(1)</sup> Acoustical Design Load



### MAIN BENEFITS



#### Flexible Design

Flexible void or hanging options starting from 80 mm.

#### Safety & Structural Integrity

Robust frame made of steel with hot-dip galvanised coating, for long-term durability.

#### Easy To Specify

Easily integrate into project documentation and workflows with ready-to-use .dwg cross-sections available online.

Specify with confidence a CE marked solution, meeting high safety and environmental protection requirements.

#### Time & Labour Savings

High load capacity allows for fewer hangers to cope with high load equipment or structures.

#### Installation Ease

Few options with large coverage, for easy inventory management and onsite selection.

Colour-coded pads or springs for easy ID onsite: right colour, no mistake.

Flexible hanging options starting from 80 mm.

# Acoustic Results

## Test Setups

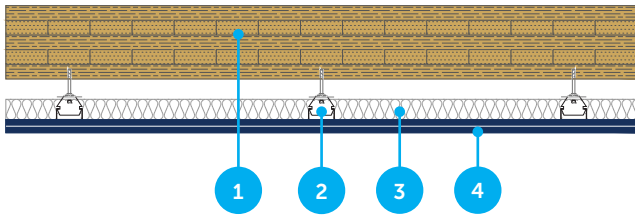

- 140 mm CLT 5-ply
- Stravilink CC60-P** clips [on 600 x 800 mm grid]
- 50 mm mineral wool
- 2x layers 18 mm gypsum boards

$L_{n,w}$	$R_w$
56 dB	67 dB

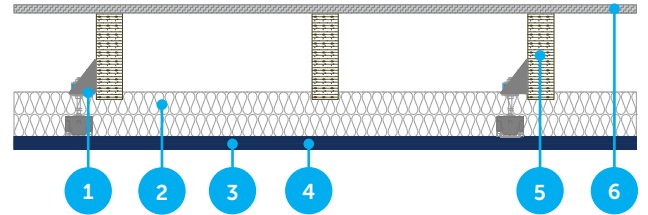

- Stravilink IJH-P**
- 100 mm mineral wool
- 2x layers 12.5 mm gypsum boards
- 3 mm Damping Layer
- 63 x 178 mm wooden joists
- 18 mm Oriented Strand Board (OSB)

$L_{n,w}$	$R_w$
56 dB	60 dB

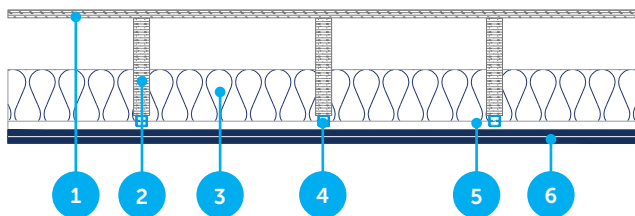

- 19 mm plywood
- 38 mm x 240 mm wood joists, spaced 406 mm on centers
- 150 mm fiberglass batt insulation
- Stravilink QRC**
- 22 mm metal hat-shaped channel
- 2x layers 16 mm plasterboard

$L_{n,w}$	$R_w$
59 dB	56 dB

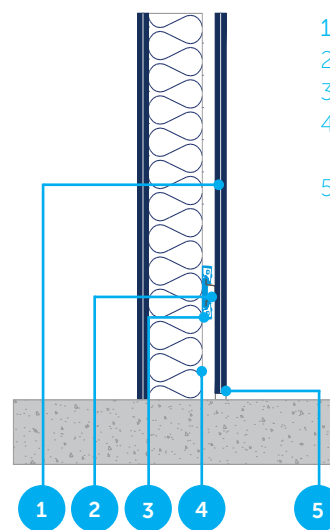

- 2x layers 15 mm plasterboard
- 30 mm furring channel
- Stravilink QRC**
- 90 mm metal stud wall with 50 mm insulation
- Perimeter Strip

$R_w$
66 dB

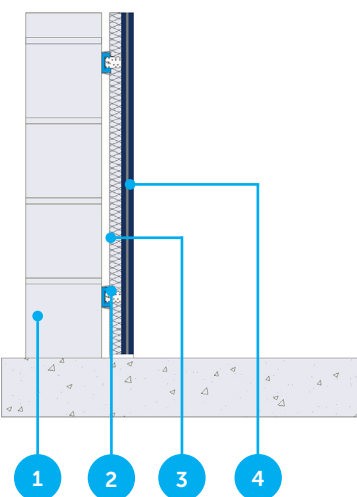

- 190 mm heavy masonry wall
- Stravilink QR**
- 50 mm total air cavity with 30 mm insulation material
- 2x layers 12.5 mm gypsum board with 3 mm Damping Layer in between

$R_w$
75 dB



Register on **Stravi-dB** to access the acoustic test reports for these and many other Stravilink assemblies. Stravi-dB is a free online library that provides not only test reports, but also editable measurement data (.csv), typical cross-sections (.dwg), and a wide range of additional documents - making it easy to integrate the solutions into your projects.

<https://stravi-db.com/>

**OR**

Detailed information on acoustic measurements can be found in the datasheet for each solution.



SCAN ME



# References

## Around the World

At CDM Stravitec, we take pride in the quality of work that we produce. Our extensive resume comprises over 10,000 projects completed since 1951.

During that time, we have made many contributions to the intelligent design and noise mitigation of buildings with our engineered products. Take a look at some of our latest projects carried out with Stravilink solutions and reputable acoustical consultants.

Our diverse project list includes recording studios, theatres, concert halls, residential buildings, manufacturing plants, medical facilities, schools, hotels, gyms, and more.



### Discovery Channel Studios

(UK)

Stravilink ISH-P

### Pumais Due Studio

(IT)

Stravifloor Deck

Stravilink

WallBatten

Stravilink ISH-S



### Palácio Ludovice Wine Experience Hotel

(PT)

Stravilink CC60-P

Stravilink DCH-P

### Vrije Universiteit Amsterdam

(NL)

Stravilink CC60-P

Stravilink IJH-P

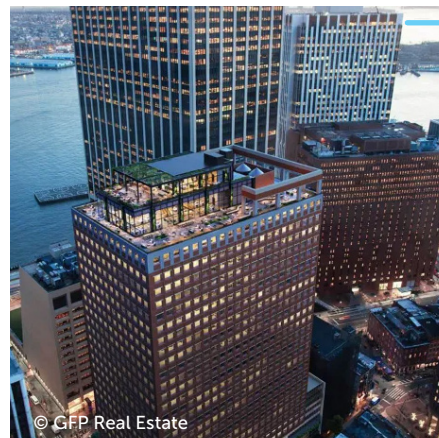

### 100 Pearl Street Squash Court

(USA)

Stravilink WallFix



We have qualified engineers in noise and vibration based at different locations around the world – they are only a phone call away. For general enquiries please contact our head office or visit our website.

**CDM Stravitec**

Reutenbeek 9-11

3090 Overijse

Belgium

T +32 2 687 79 07

info@cdm-stravitec.com

www.cdm-stravitec.com



Version 1 | 20/10/2025 - © 2025 CDM Stravitec n.v. All rights reserved.

**DISCLAIMER**

This information is accurate to the best of our knowledge at the time of issue. Information, data and recommendations provided are based on industry accepted testing and prior product usage. It is intended as descriptive of the general capabilities and performance of our products and does not endorse applicability for any particular project. We reserve the right to change products, performance, and data without notice. This document replaces all information supplied prior to the publication hereof. The renders and details present on this document are intended solely for illustration purposes only. The actual components of the final solution may undergo variations, intricately adjusted to the unique details of each project.



Vismeerstraat 3 - 5384 VL Heesch  
0800 55555 44  
info@delta-l.nl  
<https://www.delta-l.nl>

IBAN: NL79 RABO 0375036717  
BIC: RABONL2U  
BTW: NL811318539B01  
KvK: 08071864

## Delta-L B.V. | CDM Stravitec Nederland

Delta-L is specialist op het gebied van geluidsisolatie en trillingsisolatie en ontwerpt, levert en monteert diverse systemen voor akoestische ontkoppelingen in de bouw en industrie.

Delta-L vertegenwoordigt CDM Stravitec op de Nederlandse markt. CDM Stravitec is opgericht in 1951 en is marktleider op het gebied van akoestische oplegsystemen voor de bouw en industrie en is actief in tientallen landen (30+ vestigingen wereldwijd).

Door onze expertise, jarenlange ervaring en grote database aan meetresultaten van zowel interne en externe laboratorium metingen als in situ metingen hebben we door de jaren heen een uitgebreid assortiment aan akoestische materialen ontwikkeld, welke we op een slimme manier verwerken in diverse akoestische systemen.

Tevens zijn wij hierdoor in staat u adequaat van dienst te zijn bij elke stap in het proces: analyse van het geluid of trilling probleem, het aanleveren van een akoestisch ontwerp, optimalisatie van het ontwerp, productie, levering en montage.

Er wordt continu gewerkt aan innovatie en optimalisatie van de akoestische systemen om uw wensen en eisen om te zetten in een deskundig advies op maat.