

 LeEco

uMax85

User Manual

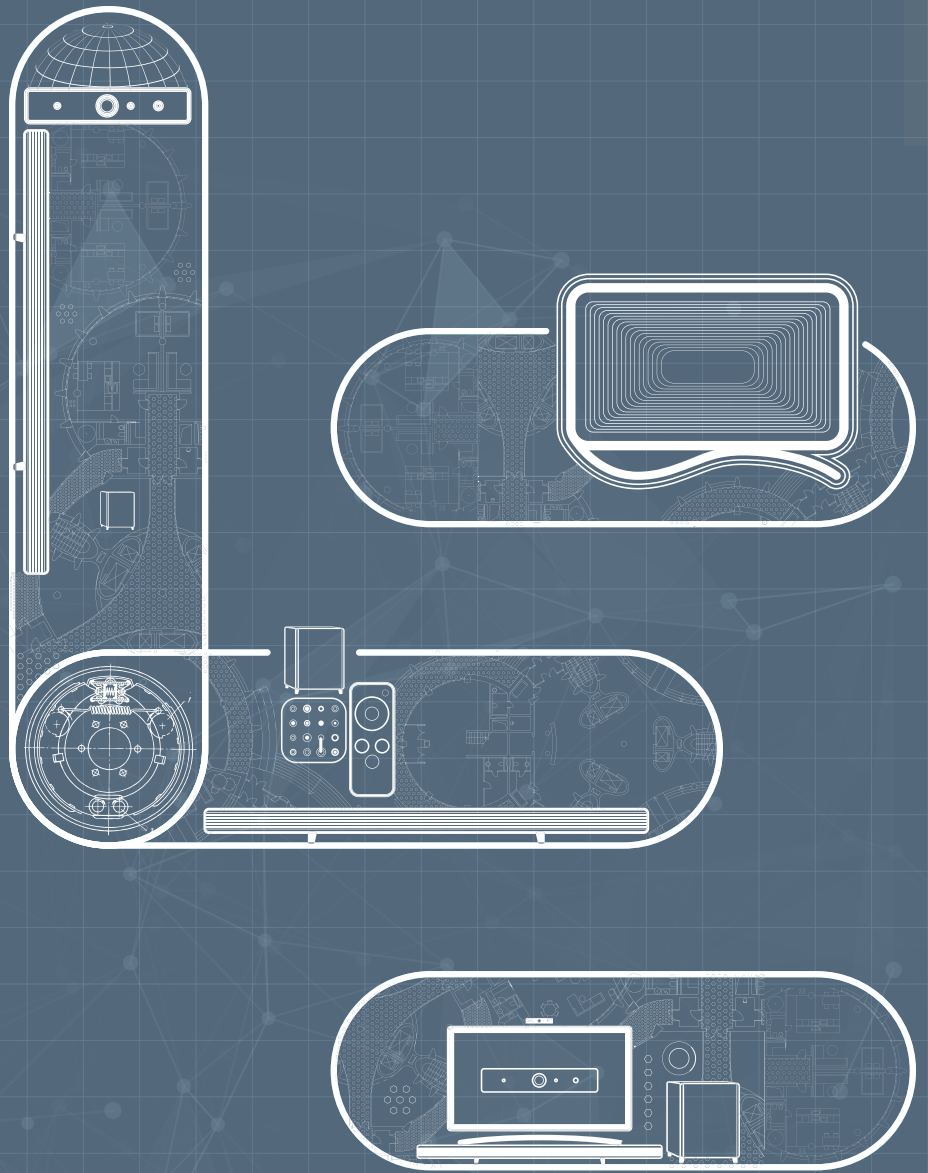

Television Without Limits

The pinnacle of in-home cinema that is every sports fan and movie lover's dream come true and the definition of television without limits, our uMax85 ecotv immerses you in 85 inches of life-sized entertainment that fills the senses. You won't be able to take your eyes off of this class-leading visual wonder.

Table of Contents

Getting Started	4
Warnings	5
What's Inside	6
Opening Instructions	7
Assembly Instructions	8
Settings	10
Connecting Your TV	11
Powering On/Off	12
Pairing the Remote Control	12
Remote Control Functions	13
Antenna Setup	14
Display	15
Sound	15
Interface & eui Apps	16
Android TV™	17
Introducing eui — Ecosystem User Interface	18
Other	19
Troubleshooting	20
Specs	21
Use & Safety	22
Certifications	23
TV Standard Limited Warranty	25

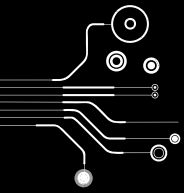
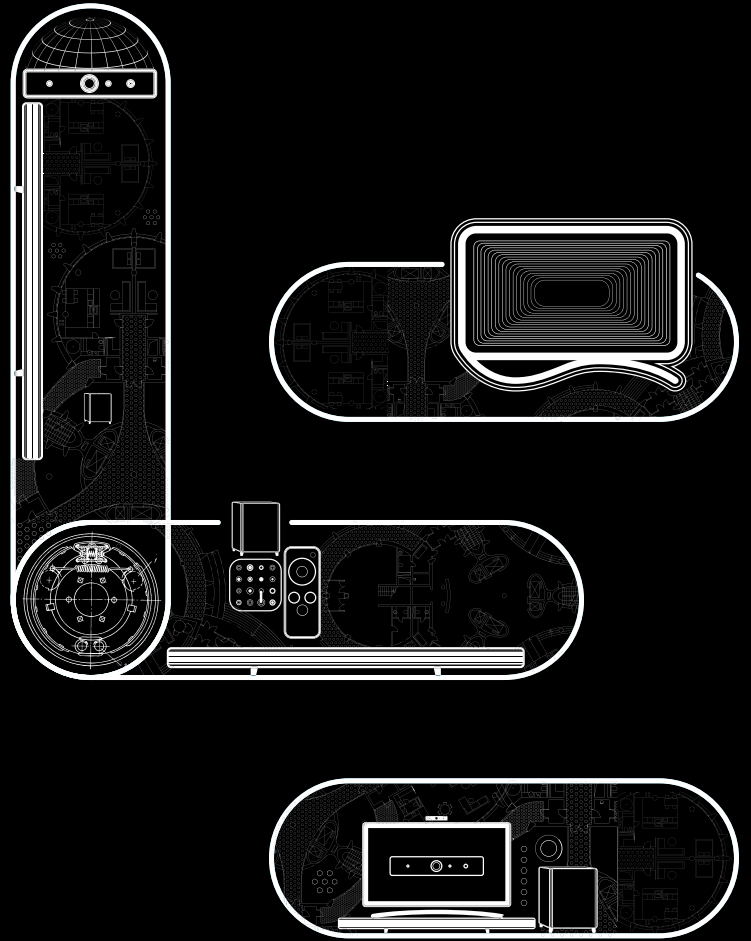

Getting Started

- Warnings
- What's Inside
- Opening Instructions
- Assembly Instructions

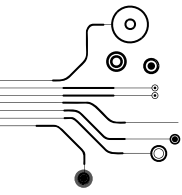



Warnings



CAUTION
ELECTRIC SHOCK DO NOT OPEN



 *The lightning flash with arrowhead symbol, within an equilateral triangle is intended to alert the user to the presence of uninsulated dangerous voltage within the product's enclosure that may be of sufficient magnitude to constitute a risk of electric shock.*

 *The exclamation point within an equilateral triangle is intended to alert the user to the presence of important operating and maintenance (servicing) instructions in the literature accompanying the appliance.*

To reduce the risk of electric shock, do not remove cover (or back). No user-serviceable parts inside. Refer servicing to qualified service personnel.

Please read and follow all instructions that come with this product. LeEco disclaims any liability for loss or damage resulting from improper use or use contrary to the product instructions.

To prevent fire or shock hazard, do not expose this appliance to rain or moisture.

To prevent electric shock do not use this polarized plug with an extension cord, receptacle or other outlet unless the blades can be fully inserted to prevent blade exposure.

These servicing instructions are for use by qualified service personnel only. To reduce the risk of electric shock, do not perform any servicing other than that contained in the operating instructions unless you are qualified to do so.

This device contains chemicals known to the State of California to cause cancer, birth defects or other reproductive harm.



RISQUE
NE PAS OUVRIR
RISQUE DE CHOC ÉLECTRIQUE



Les marquages sont inscrits en arrière de l'appareil. Les précautions d'emploi sont inscrites en arrière de l'appareil.

Pour réduire le risque d'incendie ou de choc électrique, ne pas exposer cet appareil sous la pluie et l'humidité.

L'appareil ne doit pas être exposé aux écoulements ou aux éclaboussures et aucun objet ne contenant de liquide, tel qu'un vase, ne doit être placé sur l'objet. La prise du secteur est utilisée pour déconnecter le système.

La prise du secteur ne doit pas être obstruée ou doit être facilement accessible pendant son utilisation.

Pour être complètement déconnecté de l'alimentation d'entrée, la prise doit être débranchée du secteur.

Les piles ne doivent pas être exposées à de forte chaleur, tels que la lumière du soleil, au feu ou autres choses de semblable.

Des pressions acoustiques excessives provenant d'écouteurs ou de casques peuvent provoquer des pertes de l'audition.

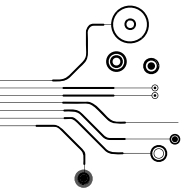

What's Inside



2 3D Glasses
w/ Batteries*

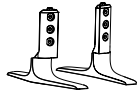

2 Stands

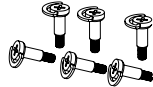

6 Bolts

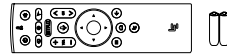

Remote &
2 AA Batteries

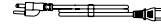

Power Cord



Cable

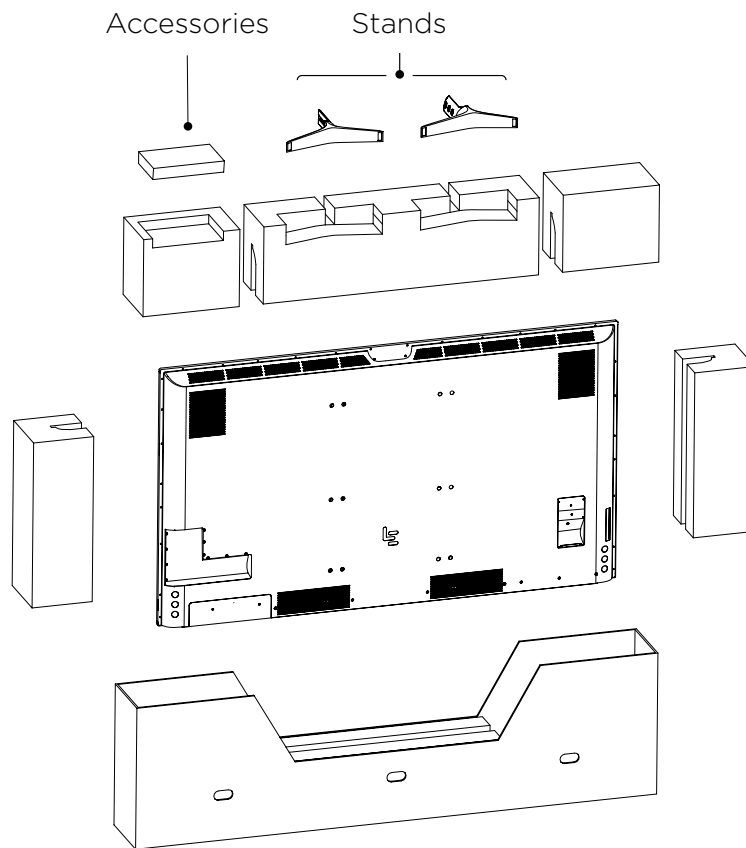

* remove battery protection to activate batteries

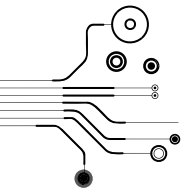

Opening Instructions

Step 1: Stand TV box upright.

Step 2: Remove lock clips (squeeze tabs inward and pull out) from **(E)**, and lift box lid from package base.

Step 3: Pull out accessories kit and stands from foam cover **(A)**.

Step 4: Remove front protective cover **(B)** from TV, and place foam side down.

Step 5: Gently tilt and lower the TV, backside down, until evenly aligned with foam cover **(B)**.

Step 6: Remove box base **(E)**.

Step 7: Remove the screws and covers from holes on each side at the bottom of the TV.

Step 8: Secure the stands to each side of TV using the bolts provided. Recommended: Place a soft covering beneath stand edges where they meet the floor.

Step 9: Remove protective foam **(A, C and D)**, and carefully lift TV upright, taking care not to press on screen.

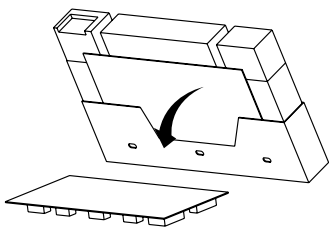
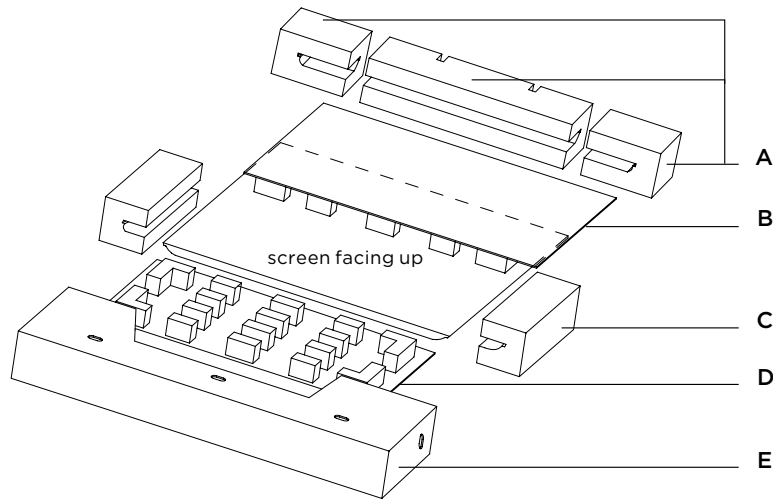

Ensure foam covers are evenly aligned (D) and (B)

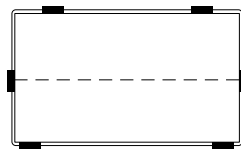

Follow diagram for hand positioning

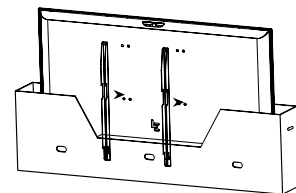

Keep box base on if installing wall mount

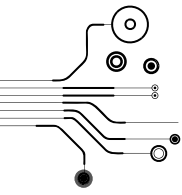

Assembly Instructions

Installing the Stand

4 people required for installation. Wear safety gloves.

Step 1: Carefully lift TV out of box. Slowly set down with screen facing up. To avoid damaging the product, use caution and refrain from pressing on screen.

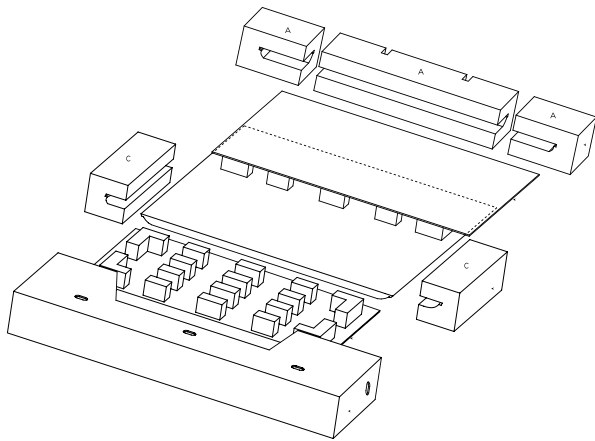

Step 3: Secure the stands to each side of TV using the bolts provided. Recommended: Place a soft covering beneath stand edges where they meet the floor.

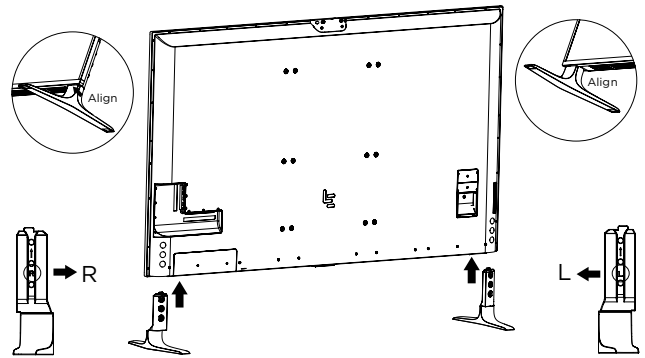

Step 2: Remove the screws and covers from holes on each side at the bottom of the TV.

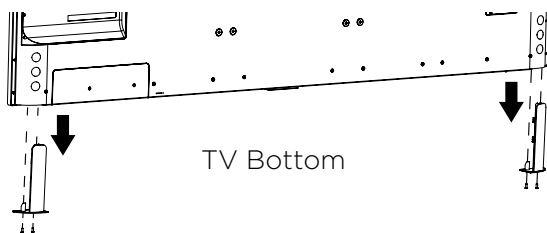

Step 4: Make sure there is enough surrounding space as indicated below.

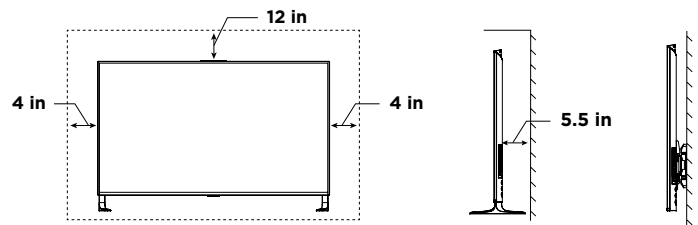

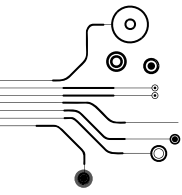

Installing a Wall Mount

It is advisable to consult a qualified professional. To avoid electric shock, power off television prior to completing these steps. LeEco maintains no liability for damages or personal injury. Before installing, ensure the wall will support the combined load of the equipment and hardware. Consult your wall mount guide for weight specifications and product-specific instructions.

- To ensure device stability, locate and align television with wall studs.
- Follow diagram to ensure proper spacing around the device.
- Four people recommended.
- Secure television to wall mount using VESA standard wall mount screw locations:
 - 400x400mm (VESA® standard)
 - 500x400mm
 - 400x700mm
 - 500x700mm

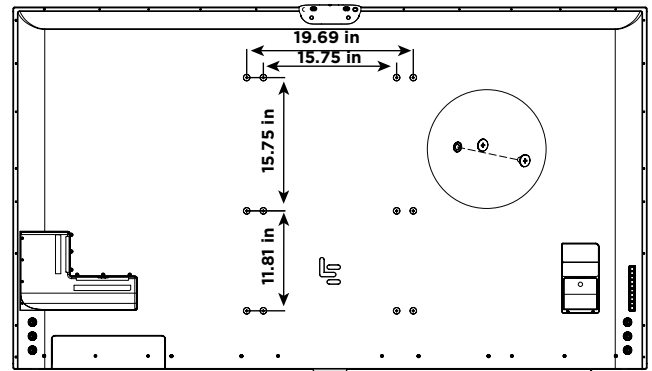
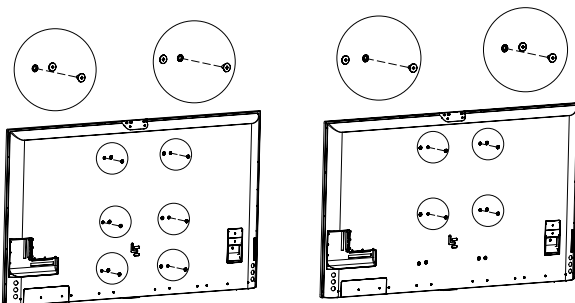
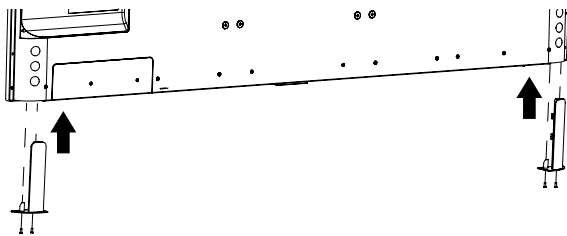

Wall Mount Screw Locations

⚠ Do not cover ventilation hole or put any object into enclosure, such as newspaper, curtain, etc.

Reserve adequate ventilation space around ecotv.

Do not place your ecotv in any place where there is vibration.

Do not place ecotv close to air conditioner. Otherwise, moisture condensation may appear on interior panel of display and damage the panel.

Do not place ecotv in any area with strong electromagnetic field, or the TV may incur damage and interference.

⚡ Contact a professional for assistance when wall mounting your TV. We are not responsible for any damage to the product or injuries. Do not power on the TV when performing wall mount installation. It may cause personal injury due to electric shock.

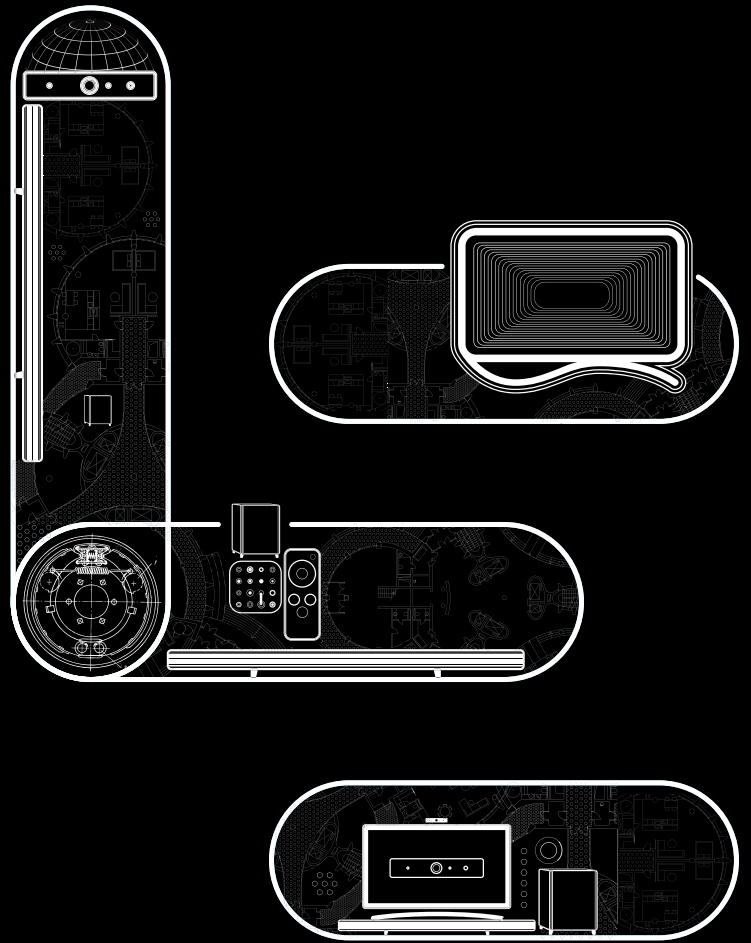

Settings

Connecting your ecotv
Powering On/Off
Pairing the Remote Control
Remote Control Functions

Antenna Setup
Display
Sound

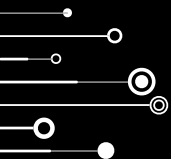

Connecting your ecotv

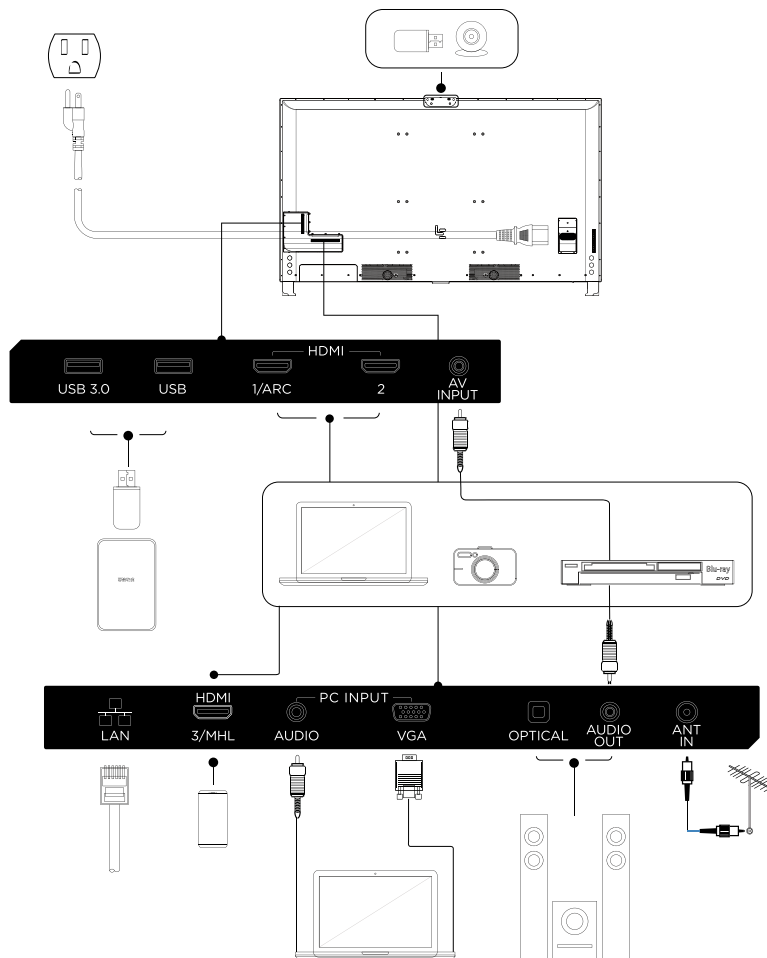

HDMI: Connect external components (such as Blu-ray and game consoles) to your TV using HDMI.

ARC (Audio Return Channel): Send a digital signal to a compatible device without the need for an additional optical audio connection.

MHL: Use this option for mobile phones and cameras.

A/V (Composite): Connect to an older-generation device, such as VCR, game consoles or DVD player, using the composite cable*.

Digital Optical Audio: Connect to external sound devices using optical audio cable.

Video Graphics Array (VGA): Use your TV as a monitor by connecting your computer with a VGA cable**.

PC Input: Connect PC audio to TV using 3.5mm audio cable (not included).

Antenna: Connect to antenna by plugging coaxial cable into the ANT IN connector.

Connecting to Internet: Connect TV to the internet using a wired (LAN) or wireless (built in Dual Band 802.11 b/g/n/ac Wi-Fi) connections.

*Male RCA cable not included. **VGA cable not included.

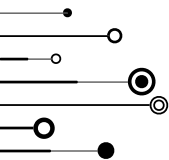

Powering On/Off

Step 1: Plug TV into a power outlet.

Step 2: Turn the switch under the TV to ON mode.

Step 3: To turn on/off the TV, press power button on your remote. **Note:** Wait about five seconds for TV to fully power on.

Step 4: A light at the bottom center of your TV indicates the power status:

Blue: TV is on

Red: TV is off

Step 5: To enter power saving mode, press and hold the power button for two seconds.

Note: Rebooting will prompt Android TV™ setup to relaunch, which can take up to 35 seconds.

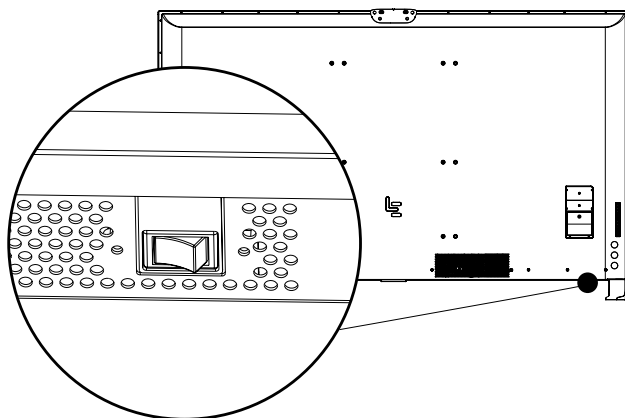

Remote Control Pairing

Slide battery cover off of remote and locate pairing button. Insert 2 AA batteries, press and hold button until connection is confirmed on screen.



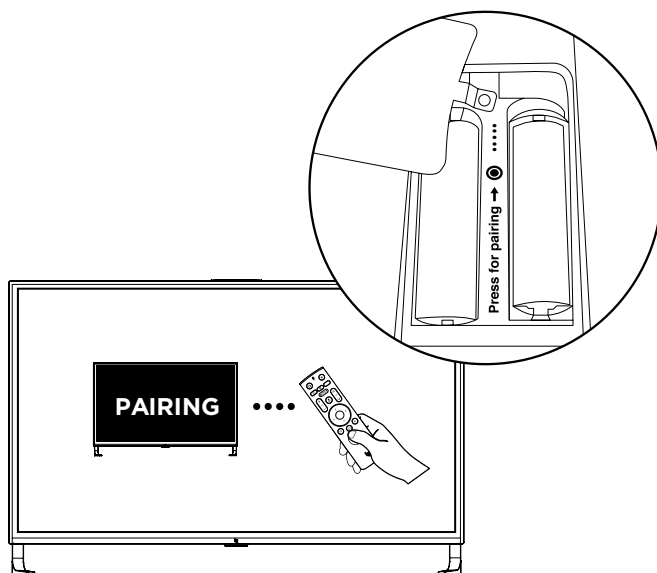

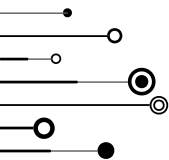



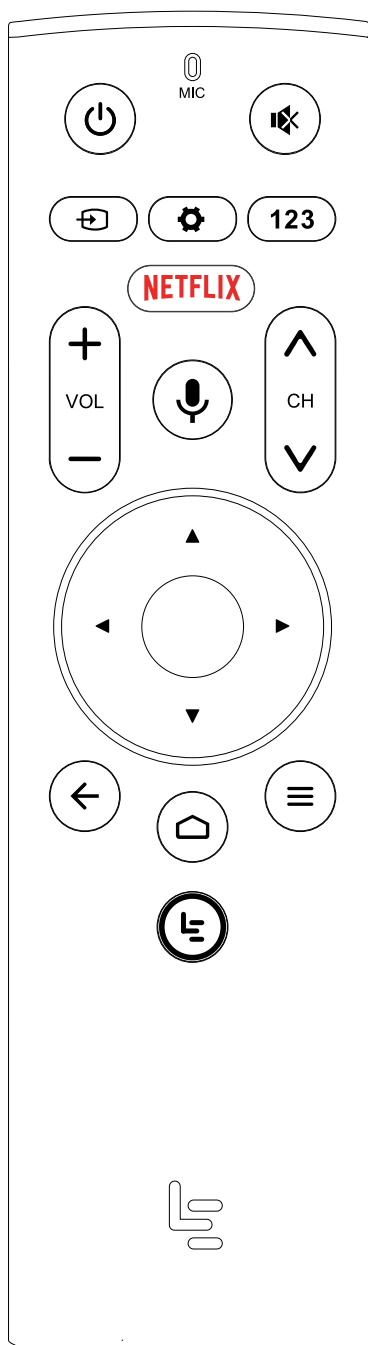





Note: In order to connect, remote must be less than eight inches from lower section of TV.





Remote Control Functions



-  Power television on or off
-  Mute sound
-  Display and select input sources
-  Display and select settings
-  Input desired channel number
-  Access Netflix
-  Increase or decrease volume
-  Activate voice commands
-  Channel up or down
-  Navigate up, down, left or right
-  Select/Enter
-  Return to previous screen
-  Display TV home page
-  Display application menu
-  Access Le

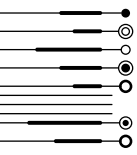

Antenna Setup

Set up an antenna to access broadcast channels.

- Plug a coaxial cable into the ANT IN connector.
- Navigate to Inputs from the home screen, and select Cable/Antenna. NOTE: If you have not programmed your TV to scan for channels using the antenna, then select Tuner from Channel Sources.
- Once in Tuner mode, select Air option.
- Follow the prompts to scan until broadcast channels display on screen.
- Connect to antenna by plugging coaxial cable into the ANT IN connector.

Channel programming guide and other features:

- To access the channel programming guide, press the Menu key on your remote, and select Program Guide.
- Use additional menu options to access other features, including Closed Captioning, Input Sources, Display Modes, Multi-Audio, Video Description, Channel Setup and Parental Controls.

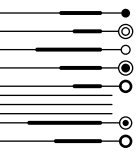

Display

By default, your TV is set to **Energy Saving Mode**. To adjust, press the Settings button on your remote, and navigate to:

Picture > Display Mode

Advanced display options, such as brightness, color and clarity, can be found by navigating from the home screen to:

Settings > Picture > Mode settings

Sound

Sound options, such as custom gaming presets, can be found by navigating from the home screen to:

Settings > Sound

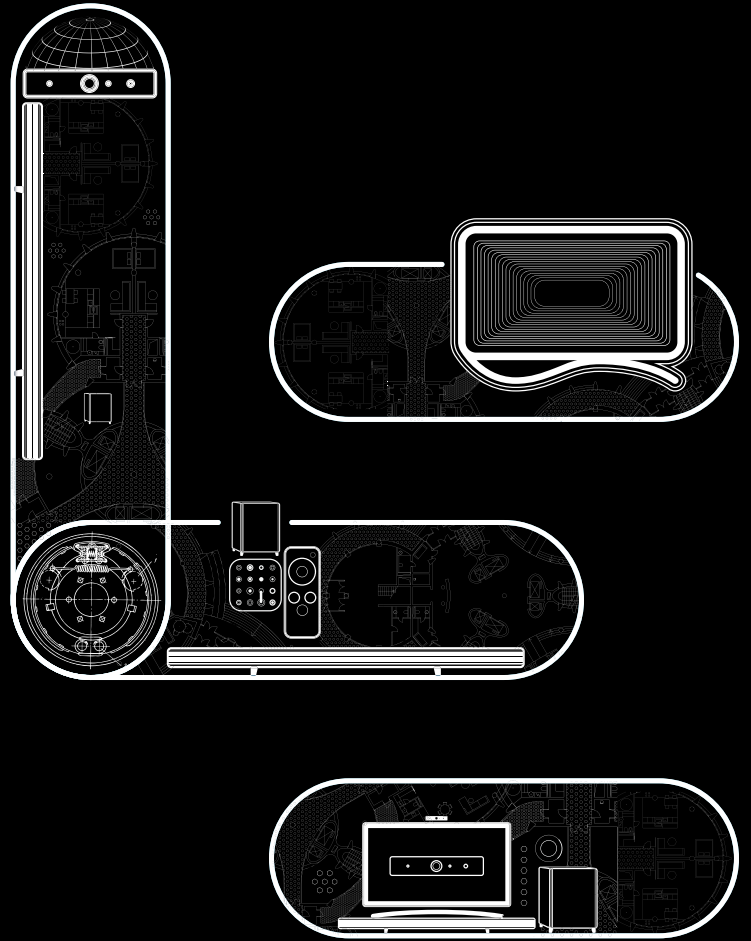

Interface & eui Apps

Android TV™
Introducing eui — Ecosystem User Interface



Android TV™

Launching your interface:

Select language: Once your device is powered on, you'll be prompted to select your preferred language.

Sync external device (optional): Transfer Google™ EcoPass membership account information from an external device.

Configure Wi-Fi: Here, you'll be asked to select your network connection and enter your Wi-Fi password. (this step will be omitted when ethernet cable is plugged into your TV)

Login with Google (optional): Logging in with Google allows you to instantly sync your account preferences and information for an enhanced experience.

Review terms and conditions: Review and accept terms and privacy disclosures.

Location services: Indicate your preferences for third party applications that request your location.

Feedback reporting: Indicate whether to generate and send automated reports on any technical issues.

Channel sources: Select input settings.



Google Voice Search™

Search through thousands of movies and shows with the press of a button — just navigate to the Google Voice Search™ icon at the top left from the home screen. You can also use the microphone shortcut button on your remote control. Simply press the button and speak a command. For example, you might say the name of your favorite actor, or “Show me action movies” for a smart list of related entertainment. Finding what you want to watch has never been simpler.

Google Cast

Cast your entertainment

Cast entertainment from smartphone to TV, instantly switch from phone to TV using built-in Google Cast™. To get started, download any Google Cast-enabled app on your phone. Sync your TV and phone to the same wireless network, and press the Cast button on your phone. Now, select your TV from the list. Entertainment will launch on your TV.



Introducing eui — Ecosystem User Interface

eui is your Ecosystem User Interface connecting all LeEco devices into a revolutionary and seamless entertainment experience.

From ecophones to cars and everything in between: power on, and you're there. An unprecedented kaleidoscope of streaming movies, shows, TV channels and more, eui features a collection of apps tailored to you. Your ecotv is more than hardware — it's an experience.



Creating a My LeEco account:

Enjoy top entertainment with a My LeEco account, which gives you premier access to exclusive feature films, international movies, shows and more. Sign up to get started:

- When prompted, select the option to create a new account. Note: If you already enjoy the benefits of My LeEco, simply log in!

Optional:

- Create a new username and password; or
- Leverage an existing Google account.

Review terms and privacy disclosures.

You're ready!



Le: Stop in. Stay a while.

Grab the popcorn and kick back with your complete media library. Your gateway to LeEco's full, unparalleled library of streaming content, Le aggregates our signature entertainment.



LIVE: Tap, and you've arrived.

A revolutionary TV viewing experience, LIVE serves up a 3x3 tiled mosaic of hand-picked, simultaneously-streaming entertainment.

Cast entertainment in an instant:

Swipe your ecophone screen during any LIVE or Le entertainment to cast on your ecotv screen.

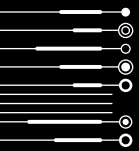
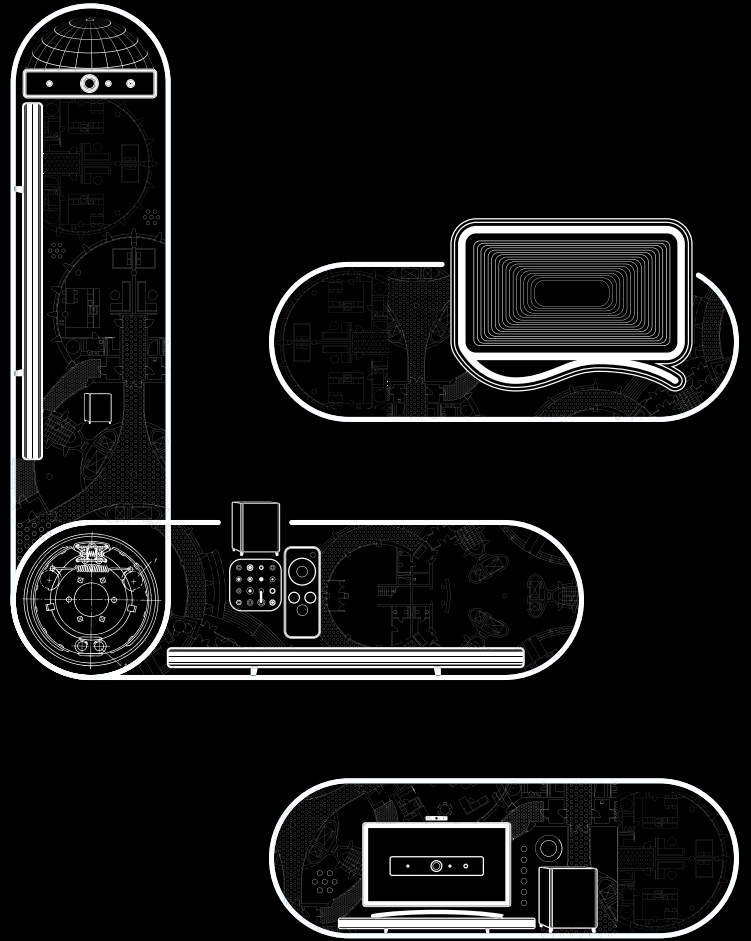

Troubleshooting & Other

Troubleshooting
Specs
Use & Safety

Certifications
TV Standard Limited Warranty

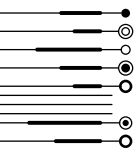

Troubleshooting

Issue:

My television isn't powering on.

Solution:

- Plug TV into a power outlet.
- Confirm that power cord is securely plugged into TV.
- Make sure the switch behind the TV is turned on.
- A blue light at the bottom of your TV indicates power is on.

The remote isn't working.

- Make sure you've inserted two AA batteries. Slide battery cover off of remote and locate pairing button.
- Press and hold pairing button until connection is confirmed onscreen.

The screen seems too dark.

- By default, your TV is set to Energy Saving mode, which impacts brightness. To adjust, press the Settings button on your remote, and navigate to:
Picture > Display Mode

Are there other display settings?

- Additional display options can be found by navigating from the home screen to:
Settings > Picture > Mode settings

I want to adjust the audio.

- From home screen, navigate to:
Settings > Sound
- There, you can adjust sound format, and volume range.

My game console (or other device) isn't connecting.

- Ensure any external components (such as Blu-ray™ and game consoles) are connected to your TV using HDMI. Use the Input selection on the Home screen to select the correct source.

I still have a question.

- Contact customer support at 855-665-3326, or visit forum.le.com

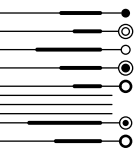

Specs: uMax85

Model	Product Model UPC Code	D85XUCNN 815493020585
Features	Size Resolution Processor OS CPU GPU HDR Flash Memory Local Dimming Fluid Motion 3D	85" (84.5" diag.) 4K UHD (3840x2160) Mstar 6A938 Android TV™ Cortex A72x2 + A53x2 1.7 GHz Multi-Core Mali-T820 Dolby Vision™ + HDR 10 64GB Full Array (448 Local Dimming Zones) 1920 Yes
Connectivity	USB HDMI Bluetooth Wi-Fi VGA	3.0x2 / 2.0x1 HDMI 2.0x3 Bluetooth® 4.1 Dual-Band 802.11 b/g/n/ac Yes
Audio	Audio Speaker	Dolby Audio™, DTS HD™ Harman Kardon®
Dimensions	with Stand (WxHxD) without Stand (WxHxD)	75.0" x 46.0" x 15.7" 75.0" x 42.8" x 2.4"
Weight	with Stand without Stand	150 lbs 141.5 lbs
Wall Mount	VESA Compatible	15.7"x7.87" (400x200mm)

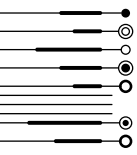

Use & Safety

1. Read these instructions.
2. Keep these instructions.
3. Heed all warnings.
4. Follow all instructions.
5. Do not use this apparatus near water.
6. Clean only with dry cloth.
7. Do not block any ventilation openings. Install in accordance with the manufacturer's instructions.
8. Do not install near any heat sources such as radiators, heat registers, stoves, or other apparatus (including amplifiers) that produce heat.
9. Protect the power cord from being walked on or pinched particularly at plugs, convenience receptacles, and the point where they exit from the apparatus.
10. Only use attachments/accessories specified by the manufacturer.
11. Use only with the cart, stand, tripod, bracket, or table specified by the manufacturer, or sold with the apparatus. When a cart is used, use caution when moving the cart/apparatus combination to avoid injury from tip-over.
12. Unplug this apparatus during lightning storms or when unused for long periods of time.
13. Refer all servicing to qualified service personnel. Service required when the apparatus has been damaged in any way, such as power supply cord or plug is damaged, liquid has been spilled or objects have fallen into the apparatus, the apparatus has been exposed to rain or moisture, does not operate normally, or has been dropped.
14. The remote control battery shall not be exposed to excessive heat such as sunshine, fire or the like
15. Excessive sound pressure from earphones and headphones can cause hearing loss.
16. Do not defeat the safety purpose of the polarized or grounding-type plug. A polarized plug

has two blades with one wider than the other. A grounding type plug has two blades and a third grounding prong. The wide blade or the third prong are provided for your safety. If the provided plug does not fit into your outlet consult an electrician for replacement of the obsolete outlet.

17. The apparatus shall not be exposed to dripping or splashing liquid and that no objects filled with liquids, such as vases, shall be placed on the apparatus.
18. The MAINS power plug or appliance coupler is used as the disconnect device, the disconnect device shall remain readily operable.
19. Caution Marking and rating plate are located at rear enclosure of the apparatus.
20. The MAINS power plug of the apparatus should not be obstructed and should be easily accessed during intended use. To be completely disconnected from the power input, the apparatus shall be disconnected from the mains power outlet.
21. Minimum distances 10cm around the apparatus for sufficient ventilation.
22. No naked flame sources, such as lighted candles, should be placed on the apparatus;
23. Attention should be drawn to the environmental aspects of battery disposal;
24. The use of apparatus in moderate climates.

RECYCLING

Because your device includes electronic parts, you must dispose of it separately from household waste when it has reached its end of life. Please consult your local laws and regulations for disposing of your device properly. Also, you can contact customer support for instructions on how to recycle your device. Please work with us to recycle in a way that helps the environment and protects all of us.

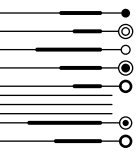

Certifications

DOLBY AUDIO™

Dolby and the double-D symbol are registered trademarks of Dolby Laboratories. All other trademarks remain the property of their respective owners.

DOLBY VISION™

Dolby® Vision™ support varies by program. Streaming content not currently supported will be supported by a future software upgrade.



For DTS patents, see <http://patents.dts.com>. Manufactured under license from DTS Licensing Limited. DTS, the Symbol, & DTS and the Symbol together are registered trademarks, and DTS Premium Sound is a trademark of DTS, Inc. © DTS, Inc. All Rights Reserved.



Mobile High-Definition Link MHL and the MHL logo are trademarks or registered trademarks or service mark of MHL, LLC in the United States and/or other countries.



The terms HDMI and HDMI High-Definition Multimedia Interface, and the HDMI Logo are trademarks or registered trademarks of HDMI Licensing, LLC in the United States and other countries.

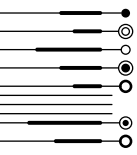

FCC CERTIFICATION

This equipment has been tested and found to comply with the limits for a Class B digital device, pursuant to Part 15 of the FCC Rules. These limits are designed to provide reasonable protection against harmful interference in a residential installation. This equipment generates, uses and can radiate radio frequency energy and, if not installed and used in accordance with the instructions, may cause harmful interference to radio communications. However, there is no guarantee that interference will not occur in a particular installation. If this equipment does cause harmful interference to radio or television reception, which can be determined by turning the equipment off and on, The user is encouraged to try to correct the interference by one of the following measures:

- Reorient or relocate the receiving antenna.
- Increase the separation between the equipment and receiver.
- Connect the equipment into an outlet on a circuit different from that to which the receiver is connected.
- Consult the dealer or an experienced radio/TV technician for help.



ENERGY STAR

1. Picture Mode (Power Saving) is the setting in which the product qualifies for ENERGY STAR®.
2. Any changes to default as-shipped television configuration and settings would change the energy consumption. And enabling certain optional features and functionalities may increase energy consumption beyond the limits required for ENERGY STAR® qualification, as applicable.
3. ENERGY STAR® is a joint program of the U.S. Environmental Protection Agency and the U.S. Department of Energy helping us all save money and protect the environment through energy efficient products and practices
4. This product has no forced menu.
5. If you want to use energy saving mode, please follow the steps below to operate.
6. To turn off your television, press and hold the power button for two seconds. Quickly press the power button to shut down the screen immediately and then enter standby mode in at most 20 minutes, depending on TV system status.

This product meets ENERGY STAR® guidelines for energy efficiency. ENERGY STAR and the ENERGY STAR mark are registered U.S. marks. ENERGY STAR is a registered mark owned by the U.S. government.

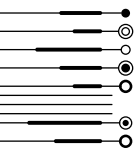

TV Standard Limited Warranty

Please read and follow all instructions that come with this product. LeEco disclaims any liability for loss or damage resulting from improper use or use contrary to the product instructions.

LeEco warrants the LeEco product and accessories against defects in materials and workmanship for twelve (12) months from the date of the original retail purchase. LeEco does not warrant against normal wear and tear, or damage caused by accident or abuse.

This warranty is valid only in the country in which the product is purchased.

For service, contact LeEco at 1-855-343-6688. Shipping charges may apply. You may be required to provide proof of purchase in submission of your warranty claim.

This Limited Warranty does not cover: (a) defects or damage resulting from accident, abuse, misuse, improper storage, exposure to liquid, excessive moisture, dampness, sand or dirt, neglect, or unusual physical, electrical or electromechanical stress; (b) scuffs, scratches, dents and other cosmetic damage; (c) equipment that has the serial number removed, defaced, damaged, altered or made illegible; (d) ordinary wear and tear; (e) defects or damage resulting from the use of product with accessories not furnished or approved by LeEco; (f) defects or damage resulting from improper maintenance, or service not furnished or approved by LeEco, which shall void this limited warranty; (g) defects or damage resulting from external causes such as, but not limited to dropping or subjecting the product to excessive physical force; OR (h) defects or damage resulting from viruses or other software problems introduced into the product. If the product contains batteries, this Limited Warranty covers batteries only if the battery leaks and this Limited Warranty does not cover any battery if the battery has been charged by a battery charger not specified or approved by LeEco.

During the warranty period, provided the product is returned in accordance with the terms of this Limited Warranty, LeEco will repair or replace the Product, at LeEco's sole option, without charge. Repaired or replaced product may be reconditioned or may contain rebuilt, refurbished or reconditioned parts or components

Replaced products will be warranted for a period equal to the remainder of the original Limited Warranty on the original product or for ninety (90) days, whichever is longer. All replaced products, parts, or components shall become the property of LeEco.

To obtain service under this Limited Warranty, you must return the Product to LeEco or to a LeEco authorized service facility accompanied by the original sales receipt or comparable proof of sale showing the original date of purchase the serial number of the Product and the seller's name and address.

If LeEco determines that any product is not covered by this Limited Warranty, you must pay LeEco for all parts, shipping, and labor charges for the repair or return of such product.

During repair or service, the contents of the memory of the product may be reformatted or deleted. You are responsible for maintaining a backup copy of any contents of the product before sending it for warranty or other service.

THIS LIMITED WARRANTY SETS OUT THE FULL EXTENT OF LEECO'S RESPONSIBILITIES AND THE SOLE AND EXCLUSIVE REMEDY REGARDING THE PRODUCT COVERED BY THIS WARRANTY. TO THE EXTENT PERMITTED BY APPLICABLE LAW, LEECO MAKES NO OTHER WARRANTIES OF ANY KIND, EXPRESS OR IMPLIED, WITH RESPECT TO THE PRODUCT, INCLUDING BUT NOT LIMITED TO ANY IMPLIED WARRANTY OF MERCHANTABILITY, FITNESS FOR A PARTICULAR PURPOSE OR AGAINST INFRINGEMENT.

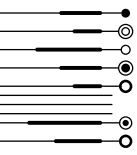

IN NO EVENT SHALL LEECO BE LIABLE FOR DAMAGES IN EXCESS OF THE PURCHASE PRICE OF THE PRODUCT OR FOR, WITHOUT LIMITATION, LOSS OF USE, DATA, OPPORTUNITY, GOODWILL, PROFITS OR SAVINGS; OR FOR INCONVENIENCE; INCIDENTAL, SPECIAL, CONSEQUENTIAL OR PUNITIVE DAMAGES; OR DAMAGES ARISING FROM THE USE OR INABILITY TO USE THE PRODUCT. SOME STATES AND JURISDICTIONS DO NOT ALLOW LIMITATIONS ON OR DISCLAIMERS OF IMPLIED WARRANTY OR ON HOW LONG AN IMPLIED WARRANTY LASTS, OR THE DISCLAIMER OR LIMITATION OF INCIDENTAL OR CONSEQUENTIAL DAMAGES, SO THE ABOVE LIMITATIONS AND DISCLAIMERS MAY NOT APPLY TO YOU.

LEECCO MAKES NO WARRANTIES OR REPRESENTATIONS, EXPRESS OR IMPLIED, STATUTORY OR OTHERWISE, AS TO THE QUALITY, CAPABILITIES, OPERATIONS, PERFORMANCE OR SUITABILITY OF ANY THIRD-PARTY EQUIPMENT, SOFTWARE OR SERVICES USED IN CONJUNCTION WITH THE PRODUCT, OR THE ABILITY TO INTEGRATE ANY OF SUCH WITH THE PRODUCT. RESPONSIBILITY FOR THE QUALITY, CAPABILITIES, OPERATION, PERFORMANCE AND SUITABILITY OF ANY SUCH THIRD-PARTY EQUIPMENT, SOFTWARE OR SERVICES IS SOLELY WITH YOU AND THE DIRECT VENDOR OR SUPPLIER OF SUCH THIRD-PARTY EQUIPMENT, SOFTWARE OR SERVICES.

Except as provided in this Limited Warranty, nothing in the product instructions or information accompanying the product or supplied by a party other than LeEco shall be construed to create an express warranty of any kind with respect to the products. No agent, employee, dealer, representative or reseller is authorized to modify or extend this Limited Warranty or to make binding representations or claims, whether in advertising, presentations or otherwise, on behalf of LeEco regarding the products or this Limited Warranty.

This Limited Warranty gives you specific legal rights, and you may also have other rights that vary from state to state. Except to any extent expressly allowed by applicable law, transfer or assignment of this Limited Warranty is prohibited.



LeEco, ecotv and uMax85 are marks or registered trademarks of LeEco or its affiliates.
Other names, trademarks or logos are the marks or registered trademarks of their respective holders.